

SERVICE MANUAL

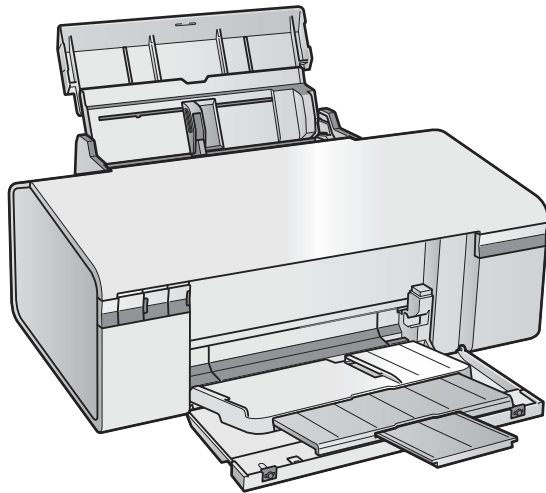

Color Inkjet Printer

EPSON Stylus Photo R280/R285/R290

EPSON
EXCEED YOUR VISION

SEIJ07003

Notice:

- All rights reserved. No part of this manual may be reproduced, stored in a retrieval system, or transmitted in any form or by any means, electronic, mechanical, photocopying, recording, or otherwise, without the prior written permission of SEIKO EPSON CORPORATION.
- The contents of this manual are subject to change without notice.
- All effort have been made to ensure the accuracy of the contents of this manual. However, should any errors be detected, SEIKO EPSON would greatly appreciate being informed of them.
- The above notwithstanding SEIKO EPSON CORPORATION can assume no responsibility for any errors in this manual or the consequences thereof.

EPSON is a registered trademark of SEIKO EPSON CORPORATION.

General Notice: Other product names used herein are for identification purpose only and may be trademarks or registered trademarks of their respective owners. EPSON disclaims any and all rights in those marks.

Copyright © 2007 **SEIKO EPSON CORPORATION.**
Imaging Products CS, PL & Environmental Management

PRECAUTIONS

Precautionary notations throughout the text are categorized relative to 1) Personal injury and 2) damage to equipment.

DANGER Signals a precaution which, if ignored, could result in serious or fatal personal injury. Great caution should be exercised in performing procedures preceded by DANGER Headings.

WARNING Signals a precaution which, if ignored, could result in damage to equipment.

The precautionary measures itemized below should always be observed when performing repair/maintenance procedures.

DANGER

1. ALWAYS DISCONNECT THE PRODUCT FROM THE POWER SOURCE AND PERIPHERAL DEVICES PERFORMING ANY MAINTENANCE OR REPAIR PROCEDURES.
2. NO WORK SHOULD BE PERFORMED ON THE UNIT BY PERSONS UNFAMILIAR WITH BASIC SAFETY MEASURES AS DICTATED FOR ALL ELECTRONICS TECHNICIANS IN THEIR LINE OF WORK.
3. WHEN PERFORMING TESTING AS DICTATED WITHIN THIS MANUAL, DO NOT CONNECT THE UNIT TO A POWER SOURCE UNTIL INSTRUCTED TO DO SO. WHEN THE POWER SUPPLY CABLE MUST BE CONNECTED, USE EXTREME CAUTION IN WORKING ON POWER SUPPLY AND OTHER ELECTRONIC COMPONENTS.
4. WHEN DISASSEMBLING OR ASSEMBLING A PRODUCT, MAKE SURE TO WEAR GLOVES TO AVOID INJURIER FROM METAL PARTS WITH SHARP EDGES.

WARNING

1. REPAIRS ON EPSON PRODUCT SHOULD BE PERFORMED ONLY BY AN EPSON CERTIFIED REPAIR TECHNICIAN.
2. MAKE CERTAIN THAT THE SOURCE VOLTAGES IS THE SAME AS THE RATED VOLTAGE, LISTED ON THE SERIAL NUMBER/RATING PLATE. IF THE EPSON PRODUCT HAS A PRIMARY AC RATING DIFFERENT FROM AVAILABLE POWER SOURCE, DO NOT CONNECT IT TO THE POWER SOURCE.
3. ALWAYS VERIFY THAT THE EPSON PRODUCT HAS BEEN DISCONNECTED FROM THE POWER SOURCE BEFORE REMOVING OR REPLACING PRINTED CIRCUIT BOARDS AND/OR INDIVIDUAL CHIPS.
4. IN ORDER TO PROTECT SENSITIVE MICROPROCESSORS AND CIRCUITRY, USE STATIC DISCHARGE EQUIPMENT, SUCH AS ANTI-STATIC WRIST STRAPS, WHEN ACCESSING INTERNAL COMPONENTS.
5. REPLACE MALFUNCTIONING COMPONENTS ONLY WITH THOSE COMPONENTS BY THE MANUFACTURE; INTRODUCTION OF SECOND-SOURCE ICs OR OTHER NON-APPROVED COMPONENTS MAY DAMAGE THE PRODUCT AND VOID ANY APPLICABLE EPSON WARRANTY.
6. WHEN USING COMPRESSED AIR PRODUCTS; SUCH AS AIR DUSTER, FOR CLEANING DURING REPAIR AND MAINTENANCE, THE USE OF SUCH PRODUCTS CONTAINING FLAMMABLE GAS IS PROHIBITED.

About This Manual

This manual describes basic functions, theory of electrical and mechanical operations, maintenance and repair procedures of the printer. The instructions and procedures included herein are intended for the experienced repair technicians, and attention should be given to the precautions on the preceding page.

Manual Configuration

This manual consists of six chapters and Appendix.

CHAPTER 1.PRODUCT DESCRIPTIONS

Provides a general overview and specifications of the product.

CHAPTER 2.OPERATING PRINCIPLES

Describes the theory of electrical and mechanical operations of the product.

CHAPTER 3.TROUBLESHOOTING

Describes the step-by-step procedures for the troubleshooting.

CHAPTER 4.DISASSEMBLY / ASSEMBLY

Describes the step-by-step procedures for disassembling and assembling the product.

CHAPTER 5.ADJUSTMENT

Provides Epson-approved methods for adjustment.

CHAPTER 6.MAINTENANCE

Provides preventive maintenance procedures and the lists of Epson-approved lubricants and adhesives required for servicing the product.

APPENDIX Provides the following additional information for reference:

- Electrical circuit boards schematics

Symbols Used in this Manual

Various symbols are used throughout this manual either to provide additional information on a specific topic or to warn of possible danger present during a procedure or an action. Be aware of all symbols when they are used, and always read NOTE, CAUTION, or WARNING messages.



Indicates an operating or maintenance procedure, practice or condition that is necessary to keep the product's quality.



Indicates an operating or maintenance procedure, practice, or condition that, if not strictly observed, could result in damage to, or destruction of, equipment.



May indicate an operating or maintenance procedure, practice or condition that is necessary to accomplish a task efficiently. It may also provide additional information that is related to a specific subject, or comment on the results achieved through a previous action.



Indicates an operating or maintenance procedure, practice or condition that, if not strictly observed, could result in injury or loss of life.



Indicates that a particular task must be carried out according to a certain standard after disassembly and before re-assembly, otherwise the quality of the components in question may be adversely affected.

Revision Status

Revision	Date of Issue	Description
A	August 8, 2007	First Release
B	September 28, 2007	[Chapter 4] <ul style="list-style-type: none">• "Main Board Unit" (Page 61): error correction. [Chapter 5] <ul style="list-style-type: none">• "Overview" (Page 107): error correction.

CONTENTS

Chapter 1 Product Description

1.1 Features.....	9
1.2 Printing Specifications.....	10
1.2.1 Basic Specifications.....	10
1.2.2 Ink Cartridge.....	10
1.2.3 Print Mode.....	11
1.2.4 Supported Paper.....	13
1.2.5 Printing Area.....	15
1.3 Interface.....	15
1.4 General Specifications.....	16
1.4.1 Electrical Specifications.....	16
1.4.2 Environmental Conditions.....	16
1.4.3 Durability.....	17
1.4.4 Acoustic Noise.....	17
1.4.5 Safety Approvals (Safety standards/EMI).....	17
1.5 Operation Buttons & Indicators (LEDs).....	18
1.5.1 Operation Buttons.....	18
1.5.2 Indicators (LEDs).....	18
1.5.3 Operation Buttons & LEDs Functions.....	18
1.5.4 Errors & Remedies.....	20

Chapter 2 Operating Principles

2.1 Overview.....	22
2.1.1 Printer Mechanism.....	22
2.1.2 Motors & Sensors.....	23
2.2 Electrical Circuit Operating Principles.....	24
2.2.1 Main Features.....	24
2.2.2 Components of Control Boards.....	24
2.2.3 Circuit Block Diagram.....	25
2.3 Banding Reduction System (BRS) / Paper Feed Amount Profile Correction (PFP).....	26

Chapter 3 Troubleshooting

3.1 Overview.....	28
3.1.1 Troubleshooting on Motors and Sensors.....	28
3.2 Warning / Error Indications.....	29
3.2.1 Error Indication Method.....	29
3.3 Troubleshooting by Error Message.....	31
3.3.1 Troubleshooting Problems with Error Messages.....	31
3.4 Troubleshooting by Symptom.....	42
3.4.1 Problems in Printing Operation.....	42
3.4.2 Power Problems.....	47
3.4.3 Ink-related Problems.....	47
3.4.4 Problems with Interfaces.....	49

Chapter 4 Disassembly/Assembly

4.1 Overview.....	51
4.1.1 Precautions.....	51
4.1.2 Tools.....	52
4.1.3 Screws.....	52
4.1.4 Making a Special Tool for CSIC Board.....	53
4.1.5 Work Completion Checklist.....	53
4.1.6 Required Preparation before Disassembly.....	56
4.1.7 Orientation Definition.....	56
4.1.8 How to Unlock the Carriage.....	56
4.1.9 Disassembly Flowchart.....	57
4.2 Removing Exterior Parts/Components.....	58
4.2.1 Printer Cover.....	58
4.2.2 Paper Support Assy.....	58
4.2.3 Stacker Assy / Stacker Cover.....	59
4.2.4 Upper Housing.....	59
4.3 Removing Control Boards.....	61
4.3.1 Main Board Unit.....	61
4.3.2 Panel Assy/ Cover Open Sensor.....	64
4.3.3 P/S Assy.....	68

4.4 Disassembling the Printer Mechanism	69
4.4.1 Removing the Printer Mechanism	69
4.4.2 Printhead	72
4.4.3 CR Scale	74
4.4.4 APG Unit	75
4.4.5 Waste Ink Tray	77
4.4.6 Waste Ink Pad	77
4.4.7 Left & Right Guide Stackers / CDR Guide Sensor	78
4.4.8 Ink System	79
4.4.9 EJ Frame Assy	80
4.4.10 PF Encoder / PF Scale	83
4.4.11 PF Motor	83
4.4.12 CR Motor	84
4.4.13 CR Unit	86
4.4.14 ASF Unit	88
4.4.15 Upper Paper Guide	90
4.4.16 APG Sensor Assy	91
4.4.17 Front Paper Guide Assy	92
4.4.18 CDR Tray Sensor	94

Chapter 5 Adjustment

5.1 Adjustment Items and Overview	96
5.1.1 Servicing Adjustment Item List	96
5.1.2 Required Adjustments	99
5.2 Using the Adjustment Program	101
5.2.1 Top Margin Adjustment	101
5.2.2 Head Angular Adjustment	101
5.2.3 Bi-D Adjustment	102
5.2.4 PW Adjustment/First Dot Position Adjustment	103
5.2.5 PF Adjustment	104
5.2.6 PG Adjustment	105
5.3 Banding Reduction System (BRS) Adjustment / Paper Feed Amount Profile (PFP) Correction	107
5.3.1 Overview	107
5.3.2 Adjustment Procedure	109

Chapter 6 Maintenance

6.1 Overview	113
6.1.1 Cleaning	113
6.1.2 Service Maintenance	113
6.1.3 Lubrication	114

Chapter 7 Appendix

7.1 Exploded Diagram / Parts List	121
7.2 Electrical Circuits	121

DURAKLIN

CHAPTER

1

PRODUCT DESCRIPTION

1.1 Features

EPSON Stylus Photo R280/R285/R290 are single-function color ink-jet printers. The main features are;

- High speed & High quality
 - Maximum print resolution: MGA 5760 (H) x 1440 (V) dpi
 - Newly developed F3 Mach Turbo II print head achieves higher print speed than ever.
 - Six independent dye-ink cartridges enables high-resolution photo printing.
 - CD and DVD label printing are supported.
 - Borderless printing on specified EPSON brand paper is available.
- Control panel
Simple design with three buttons and three indicators (LED).
- Dimensions
 - Dimensions: 450 mm (W) x 282 mm (D) x 187 mm (H)
(Paper support and stacker are closed. Rubber feet are included)
 - Weight: 5.4 kg (without ink cartridges)

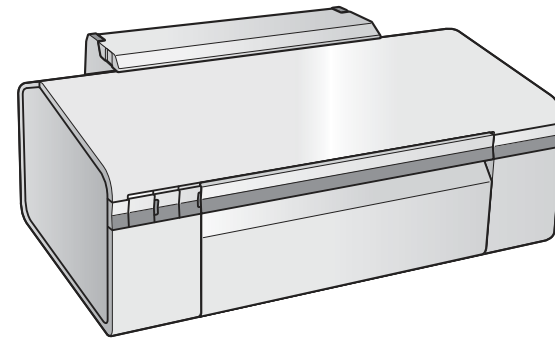

Paper Support & Stacker are Closed

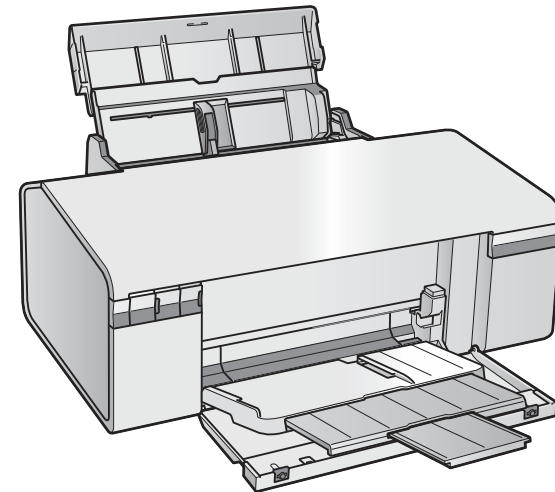

Paper Support & Stacker are Opened

Figure 1-1. External View

1.2 Printing Specifications

1.2.1 Basic Specifications

Table 1-1. Printer Specifications

Item	Specifications
Print method	On-demand ink jet
Nozzle configuration	Black: 90 nozzles Color: 90 nozzles x 5 (Cyan, Magenta, Yellow, Light Cyan, Light Magenta)
Print direction	Bi-directional minimum distance printing, unidirectional printing
Print resolution	Horizontal x Vertical (dpi) • 360 x 180 • 720 x 540 • 360 x 360 • 720 x 720 • 720 x 360 • MGA 5760 x 1440 (1440 x 1440)
Control code	• ESC/P Raster command • EPSON Remote command
Internal font	Character code: Alphanumeric with expanded graphics (PC437) ASCII, 20H to 7FH only Font: EPSON original font Alphanumeric font: Courier
Paper feed method	Friction feed, using one ASF (Auto Sheet Feeder)
Paper path	Top feed, front out
Paper feed rates	110 msec (at 25.4 mm feed)
PF interval	Programmable in 0.01764 mm (1/1440 inch) steps

1.2.2 Ink Cartridge

The product numbers of the EPSON ink cartridges for this printer are shown below.

Table 1-2. Product No. of Ink Cartridges

Color	EAI	Euro	Asia, CISMEA, Latin
Black	T0771 (S) T0781 (SS)	T0801	T0811 (S) T0821 (SS)
Cyan	T0772 (S) T0782 (SS)	T0802	T0812 (S) T0822 (SS)
Magenta	T0773 (S) T0783 (SS)	T0803	T0813 (S) T0823 (SS)
Yellow	T0774 (S) T0784 (SS)	T0804	T0814 (S) T0824 (SS)
Light Cyan	T0775 (S) T0785 (SS)	T0805	T0815 (S) T0825 (SS)
Light Magenta	T0776 (S) T0786 (SS)	T0806	T0816 (S) T0826 (SS)

- Shelf life
Two years from production date (if unopened), six months after opening package.
- Storage Temperature

Table 1-3. Storage Temperature

Situation	Storage Temperature	Limit
When stored in individual boxes	-20 °C to 40 °C (-4°F to 104°F)	1 month max. at 40 °C (104°F)
When installed in main unit	-20 °C to 40 °C (-4°F to 104°F)	

- Dimension
12.7 mm (W) x 68 mm (D) x 47 mm (H)



- The ink cartridge cannot be refilled.
- Do not use expired ink cartridges.
- The ink in the ink cartridge freezes at -16 °C (3.2 °F). It takes about three hours under 25 °C (77°F) until the ink thaws and becomes usable.

1.2.3 Print Mode

Table 1-4. Print Mode (Color)

Media	Print Mode	Resolution (H x V) dpi	Dot Size (cps)*1	Bi-d	Micro Weave	Border-less
<ul style="list-style-type: none"> Plain paper Premium Bright White Paper (EAI) Bright White Inkjet Paper (others) 	Draft	360x180	Eco (400cps)	ON	OFF	N/A
	Normal	360x360	MC2-1 (360cps)	ON	OFF	N/A
	Photo Fine	720x720	MC1-1 (240cps)	ON	ON	N/A
<ul style="list-style-type: none"> Ultra Premium Photo Paper Glossy (EAI) Ultra Glossy Photo Paper (others) 	Photo*2	720x720 (1.5 pass)	MC1-2 (240cps)	ON	ON	OK
	Photo*2	720x720 (2.0 pass)	MC2-2 (280cps)	ON	ON	OK
	Super Photo	1440x1440	MC1-5 (200cps)	ON	ON	OK
<ul style="list-style-type: none"> Premium Photo Paper Glossy (EAI) Premium Glossy Photo Paper (others) Premium Photo Paper Semi-gloss (EAI) Premium Semigloss Photo Paper (others) 	Fine	720x360	MC1-1 (240cps)	ON	ON	OK
	Photo*2	720x720 (1.5 pass)	MC1-2 (240cps)	ON	ON	OK
	Photo*2	720x720 (2.0 pass)	MC2-2 (280cps)	ON	ON	OK
	Super Photo	1440x1440	MC1-5 (200cps)	ON	ON	OK
<ul style="list-style-type: none"> Photo Paper Glossy (EAI) Glossy Photo Paper (others) 	Fine	720x360	MC1-1 (240cps)	ON	ON	OK
	Photo*2	720x720 (1.5 pass)	MC1-2 (240cps)	ON	ON	OK
	Photo*2	720x720 (2.0 pass)	MC2-2 (280cps)	ON	ON	OK
	Super Photo	1440x1440	MC1-5 (200cps)	ON	ON	OK
<ul style="list-style-type: none"> Premium Presentation Paper Matte (EAI) Matte Paper Heavy-weight (others) 	Photo*2	720x720 (2.0 pass)	MC2-2 (280cps)	ON	ON	OK
	Super Photo	1440x1440	MC1-5 (200cps)	ON	ON	OK

Table 1-4. Print Mode (Color)

Media	Print Mode	Resolution (H x V) dpi	Dot Size (cps)*1	Bi-d	Micro Weave	Border-less
<ul style="list-style-type: none"> Presentation Paper Matte (EAI) Photo Quality Inkjet Paper (others) 	Photo*2	720x720 (2.0 pass)	MC2-2 (280cps)	ON	ON	N/A
	Normal	360x360	MC2-1 (360cps)	OFF	OFF	N/A
<ul style="list-style-type: none"> Envelopes 	Photo Fine	720x720	MC1-1 (240cps)	OFF	ON	N/A
	Normal	360x360	MC2-1 (360cps)	OFF	OFF	N/A
<ul style="list-style-type: none"> Iron-On Transfer Paper (EAI) Ion-On Cool Peel Transfer Paper (Other) 	Photo Fine	720x720	MC1-1 (240cps)	OFF	ON	N/A
	Normal	360x360	MC2-1 (360cps)	OFF	OFF	N/A
<ul style="list-style-type: none"> Photo Stickers 	Photo*2	720x720 (2.0 pass)	MC2-2 (280cps)	ON	ON	N/A
<ul style="list-style-type: none"> CD/DVD 	Super Photo	1440x1440	MC1-5 (200cps)	ON	ON	N/A
<ul style="list-style-type: none"> CD/DVD Premium Surface 	Super Photo	1440x1440	MC1-5 (200cps)	ON	ON	N/A

Note *1: cps = character per second

*2: In Photo mode, either of 1.5 or 2.0 pass is selected depending on the paper size.
 1.5 pass supported size: 4"x6"
 2.0 pass supported size: 5"x7", 8" x 10", Letter, A4

Table 1-5. Print Mode (Monochrome)

Media	Print Mode	Resolution (H x V) dpi	Dot Size (cps)*1	Bi-d	Micro Weave	Border-less
<ul style="list-style-type: none"> • Plain paper • Premium Bright White Paper (EAI) • Bright White Inkjet Paper (others) 	Draft	360x180	Eco (400cps)	ON	OFF	N/A
	Normal	360x360	MC2-1 (360cps)	ON	OFF	N/A
	Photo Fine	720x720	MC1-1 (240cps)	ON	ON	N/A
<ul style="list-style-type: none"> • Ultra Premium Photo Paper Glossy (EAI) • Ultra Glossy Photo Paper (others) 	Photo*2	720x720 (1.5 pass)	MC1-2 (240cps)	ON	ON	OK
	Photo*2	720x720 (2.0 pass)	MC2-2 (280cps)	ON	ON	OK
	Super Photo	1440x1440	MC1-5 (200cps)	ON	ON	OK
<ul style="list-style-type: none"> • Premium Photo Paper Glossy (EAI) • Premium Glossy Photo Paper (others) • Premium Photo Paper Semi-gloss (EAI) • Premium Semigloss Photo Paper (others) 	Fine	720x360	MC1-1 (240cps)	ON	ON	OK
	Photo*2	720x720 (1.5 pass)	MC1-2 (240cps)	ON	ON	OK
	Photo*2	720x720 (2.0 pass)	MC2-2 (280cps)	ON	ON	OK
	Super Photo	1440x1440	MC1-5 (200cps)	ON	ON	OK
<ul style="list-style-type: none"> • Photo Paper Glossy (EAI) • Glossy Photo Paper (others) 	Fine	720x360	MC1-1 (240cps)	ON	ON	OK
	Photo*2	720x720 (1.5 pass)	MC1-2 (240cps)	ON	ON	OK
	Photo*2	720x720 (2.0 pass)	MC2-2 (280cps)	ON	ON	OK
	Super Photo	1440x1440	MC1-5 (200cps)	ON	ON	OK
<ul style="list-style-type: none"> • Premium Presentation Paper Matte (EAI) • Matte Paper Heavy-weight (others) 	Photo*2	720x720 (2.0 pass)	MC2-2 (280cps)	ON	ON	OK
	Super Photo	1440x1440	MC1-5 (200cps)	ON	ON	OK

Table 1-5. Print Mode (Monochrome)

Media	Print Mode	Resolution (H x V) dpi	Dot Size (cps)*1	Bi-d	Micro Weave	Border-less
<ul style="list-style-type: none"> • Presentation Paper Matte (EAI) • Photo Quality Inkjet Paper (others) 	Photo*2	720x720 (2.0 pass)	MC2-2 (280cps)	ON	ON	N/A
	Normal	360x360	MC2-1 (360cps)	OFF	OFF	N/A
<ul style="list-style-type: none"> • Envelopes 	Photo Fine	720x720	MC1-1 (240cps)	OFF	ON	N/A
	Normal	360x360	MC2-1 (360cps)	OFF	OFF	N/A
<ul style="list-style-type: none"> • Iron-On Transfer Paper (EAI) • Ion-On Cool Peel Transfer Paper (Other) 	Photo Fine	720x720	MC1-1 (240cps)	OFF	ON	N/A
	Normal	360x360	MC2-1 (360cps)	OFF	OFF	N/A
<ul style="list-style-type: none"> • Photo Stickers 	Photo*2	720x720 (2.0 pass)	MC2-2 (280cps)	ON	ON	N/A
<ul style="list-style-type: none"> • CD/DVD 	Super Photo	1440x1440	MC1-5 (200cps)	ON	ON	N/A
<ul style="list-style-type: none"> • CD/DVD Premium Surface 	Super Photo	1440x1440	MC1-5 (200cps)	ON	ON	N/A

Note *1: cps = character per second

*2: In Photo mode, either of 1.5 or 2.0 pass is selected depending on the paper size.
 1.5 pass supported size: 4"x6"
 2.0 pass supported size: 5"x7", 8" x 10", Letter, A4

1.2.4 Supported Paper

The table below lists the paper type and sizes supported by the printer. The Supported paper type and sizes vary depending on destinations (between EAI, EUR, and Asia).

Table 1-6. Supported Paper

Paper Name	Paper Size		Thickness	Weight		EAI		EUR		Asia	
			mm	g/m ²	lb.	P*1	B*2	P*1	B*2	P*1	B*2
Plain paper	Legal	215.9 x 355.6 mm (8.5"x14")	0.08-0.11	64-90	17-24	Y	-	Y	-	Y	-
	Letter	215.9 x 279.4 mm (8.5"x11")				Y	-	Y	-	Y	-
	A4	210 x 297 mm (8.3"x11.7")				Y	-	Y	-	Y	-
	B5	182 x 257 mm (7.2"x10.1")				-	-	Y	-	Y	-
	A5	148 x 210 mm (5.8"x8.3")				-	-	Y	-	Y	-
	Half Letter	139.7 x 215.9 mm (5.5"x8.5")				Y	-	-	-	-	-
	A6	105 x 148 mm (4.1"x5.8")				Y	-	Y	-	Y	-
	User Defined	89 x 127- 329 x 1117.6 mm (3.56"x 5.08" - 13.16"x44.7")				Y	-	Y	-	Y	-
Premium Inkjet Plain Paper	A4	210 x 297 mm (8.3"x11.7")	0.11	80	21	-	-	Y	-	Y	-
Premium Bright White Paper (EAI)	Letter	215.9 x 279.4 mm (8.5"x11")	0.11	90	24	Y	-	-	-	-	-
Bright White Inkjet Paper (others)	A4	210 x 297 mm (8.3"x11.7")	0.13	92.5	25	-	-	Y	-	Y	-
Ultra Premium Photo Paper Glossy (EAI) Ultra Glossy Photo Paper (others)	Letter	215.9 x 279.4 mm (8.5"x11")	0.30	290	77	Y	Y	-	-	-	-
	A4	210 x 297 mm (8.3"x11.7")				-	-	Y	Y	Y	Y
	8" x 10"	203.2 x 254 mm				Y	Y	-	-	-	-
	5" x 7"	127 x 178 mm				Y	Y	Y	Y	-	-
	4" x 6"	101.6 x 152.4 mm				Y	Y	Y	Y	Y	Y
Premium Photo Paper Glossy (EAI) Premium Glossy Photo Paper (others)	Letter	215.9 x 279.4 mm (8.5"x11")	0.27	255	68	Y	Y	-	-	-	-
	A4	210 x 297 mm (8.3"x11.7")				Y	Y	Y	Y	Y	Y
	8" x 10"	203.2 x 254 mm				Y	Y	-	-	-	-
	5" x 7"	127 x 178 mm				Y	Y	Y	Y	Y	Y
	4" x 6"	101.6 x 152.4 mm				Y	Y	Y	Y	Y	Y
	16:9 wide	102 x 181 mm (4"x7.11")				-	-	Y	-	-	-

Note *1: "Y" in the "P" column stands for "the paper type/size is Supported". "Y" in the "B" column stands for "Borderless printing is available".

Table 1-6. Supported Paper

Paper Name	Paper Size		Thickness	Weight		EAI		EUR		Asia	
			mm	g/m ²	lb.	P*1	B*2	P*1	B*2	P*1	B*2
Photo Paper Glossy (EAI) Glossy Photo Paper (others)	Letter	215.9 x 279.4 mm (8.5"x11")	0.25	258	68	Y	Y	-	-	-	-
	A4	210 x 297 mm (8.3"x11.7")				Y	Y	Y	Y	Y	Y
	5" x 7"	127 x 178 mm				-	-	Y	Y	-	-
	4" x 6"	101.6 x 152.4 mm				Y	Y	Y	Y	Y	Y
Premium Photo Paper Semi-gloss (EAI) Premium Semigloss Photo Paper (others)	Letter	215.9 x 279.4 mm (8.5"x11")	0.27	250	66	Y	Y	-	-	-	-
	A4	210 x 297 mm (8.3"x11.7")				-	-	Y	Y	Y	Y
	4" x 6"	101.6 x 152.4 mm				Y	Y	Y	Y	Y	Y
Ultra Premium Photo Paper Luster	Letter	215.9 x 279.4 mm (8.5"x11")	0.27	250	66	Y	Y	-	-	-	-
Premium Presentation Paper Matte (EAI) Matte Paper Heavy-weight (others)	Letter	215.9 x 279.4 mm (8.5"x11")	0.23	167	44	Y	Y	-	-	-	-
	A4	210 x 297 mm (8.3"x11.7")				-	-	Y	Y	Y	Y
	8" x 10"	203.2 x 254 mm				Y	Y	-	-	-	-
Double-sided Matte Paper	Letter	215.9 x 279.4 mm (8.5"x11")	0.22	185	49	Y	-	-	-	-	-
	A4	210 x 297 mm (8.3"x11.7")				-	-	Y	-	Y	-
Presentation Paper Matte (EAI) Photo Quality Inkjet Paper (others)	Letter	215.9 x 279.4 mm (8.5"x11")	0.12	102	27	Y	-	-	-	-	-
	A4	210 x 297 mm (8.3"x11.7")				Y	-	Y	-	Y	-
Envelopes	#10	104.8 x 241.3 mm (4.125"x9.5")	-	75-90	20-24	Y	-	Y	-	Y	-
	#DL	110 x 220 mm				-	-	Y	-	Y	-
	#C6	114 x 162 mm				-	-	Y	-	Y	-
Iron-On Transfer Paper (EAI) Iron-On Cool Peel Transfer Paper (Other)	Letter	215.9 x 279.4 mm (8.5"x11")	0.14	130	35	Y	-	-	-	-	-
	A4	210 x 297 mm (8.3"x11.7")				-	-	Y	-	Y	-
Photo Stickers 16	A6	105 x 148 mm (4.1"x5.8")	0.19	-	-	-	-	-	-	Y	-
Photo Stickers 4	A6	105 x 148 mm (4.1"x5.8")	0.19	-	-	-	-	-	-	Y	-
CD/DVD CD/DVD Premium Surface	ø12cm	ø12cm	-	-	-	Y	-	Y	-	Y	-
	ø8cm	ø8cm	-	-	-	Y	-	Y	-	Y	-

Note *1: "Y" in the "P" column stands for "the paper type/size is supported". "Y" in the "B" column stands for "Borderless printing is available".



- Make sure the paper is not wrinkled, fluffed, torn, or folded.
- The curve of paper must be 5 mm or below.
- When printing on an envelope, be sure the flap is folded neatly.
- Do not use the adhesive envelopes.
- Do not use double envelopes and cellophane window envelopes.

1.2.5 Printing Area

The printing area for this printer is shown below.

Table 1-7. Printing Area (Margins)

Print Mode	Paper Size	Margin			
		Left	Right	Top	Bottom
Standard print	Any size	3 mm	3 mm	3 mm	3 mm
	Envelope	5 mm	5 mm	3 mm	20 mm
Borderless print	A4/Letter to 5" x 7"	2.54 mm*	2.54 mm*	2.96 mm*	4.02 mm*
	4" x 6"			1.34 mm*	2.54 mm*
	Card	1.83mm*	1.83mm*	2.54mm*	3.53mm*

Note *: The margins for Borderless print are margins that bleed off the edges of paper.

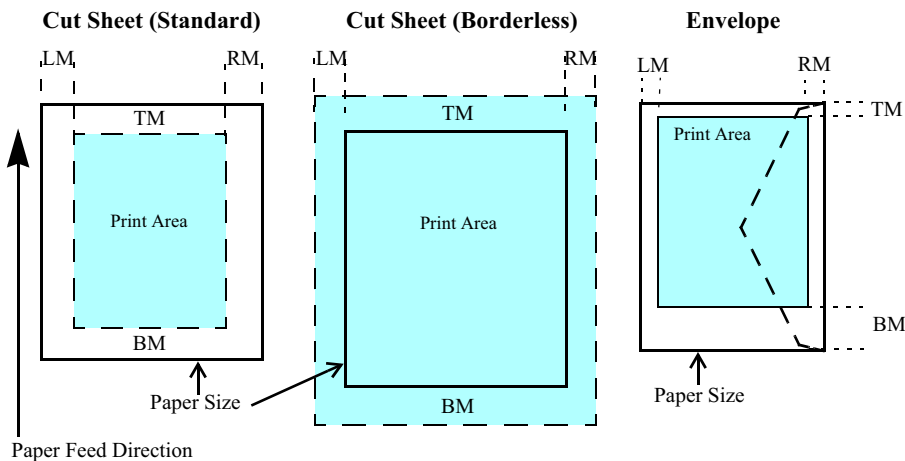

Figure 1-2. Printing Area

1.3 Interface

The printer has a USB interface of the following specification.

- Standards
 - “Universal Serial Bus Specifications Revision 2.0”
 - “Universal Serial Bus Device Class Definition for Printing Devices Version 1.1”
- Transfer rate: 480 Mbps (High Speed Device)
- Data format: NRZI
- Compatible connector: USB Series B
- Recommended cable length: 2 [m] or less

Table 1-8. Device ID

Product Name	When IEEE 1284.4 is Enabled	When IEEE 1284.4 is Disabled
Stylus Photo R280	MFG:EPSON; CMD:ESCPL2,BDC,D4,D4PX; MDL:Stylus[SP]Photo[SP]R280; CLS:PRINTER; DES:EPSON[SP]Stylus[SP]Photo [SP]R280;	MFG:EPSON; CMD:ESCPL2,BDC; MDL:Stylus[SP]Photo[SP]R280; CLS:PRINTER;
Stylus Photo R285	MFG:EPSON; CMD:ESCPL2,BDC,D4,D4PX; MDL:Stylus[SP]Photo[SP]R285; CLS:PRINTER; DES:EPSON[SP]Stylus[SP]Photo [SP]R285;	MFG:EPSON; CMD:ESCPL2,BDC; MDL:Stylus[SP]Photo[SP]R285; CLS:PRINTER;
Stylus Photo R290	MFG:EPSON; CMD:ESCPL2,BDC,D4,D4PX; MDL:Stylus[SP]Photo[SP]R290; CLS:PRINTER; DES:EPSON[SP]Stylus[SP]Photo [SP]R290;	MFG:EPSON; CMD:ESCPL2,BDC; MDL:Stylus[SP]Photo[SP]R290; CLS:PRINTER;

1.4 General Specifications

1.4.1 Electrical Specifications

- Primary power input

Table 1-9. Primary Power Specifications

Item		100-120V model	220-240V model
Rated power supply voltage		100 to 120 VAC	220 to 240 VAC
Input voltage range		90 to 132 VAC	198 to 264 VAC
Rated current		0.6 A (max. 1.0 A)	0.3 A (max. 0.5 A)
Rated frequency		50 to 60 Hz	
Input frequency range		49.5 to 60.5 Hz	
Insulation resistance		3000 V (for one minute)	
Energy conservation		International Energy Star Program compliant	
Power consumption	Printing (ISO10561 Letter Pattern)	Approx. 12 W	Approx. 12 W
	Sleep mode	Approx. 1.0 W	Approx. 1.2 W
	Standby mode (power-off)	Approx. 0.2 W	Approx. 0.3 W

Note : If the printer is not operated for more than three minutes, the printer shifts into the standby mode and reduces the current to the motor to conserve power.

1.4.2 Environmental Conditions

Table 1-10. Environmental Conditions

Condition	Temperature*1	Humidity*1,2	Shock	Vibration
Operating	10 to 35°C (50 to 95°F)	20 to 80%	1G (1 msec or less)	0.15G, 10 to 55Hz
Storage*3 (unpacked)	-20 to 40°C*4 (-4°F to 104°F)	5 to 85%	2G (2 msec or less)	0.50G, 10 to 55Hz

Note *1: The combined Temperature and Humidity conditions must be within the blue-shaded range in Fig.1-3.

*2: No condensation

*3: Non-operating with unpacked.

*4: Must be less than 1 month under 40°C.

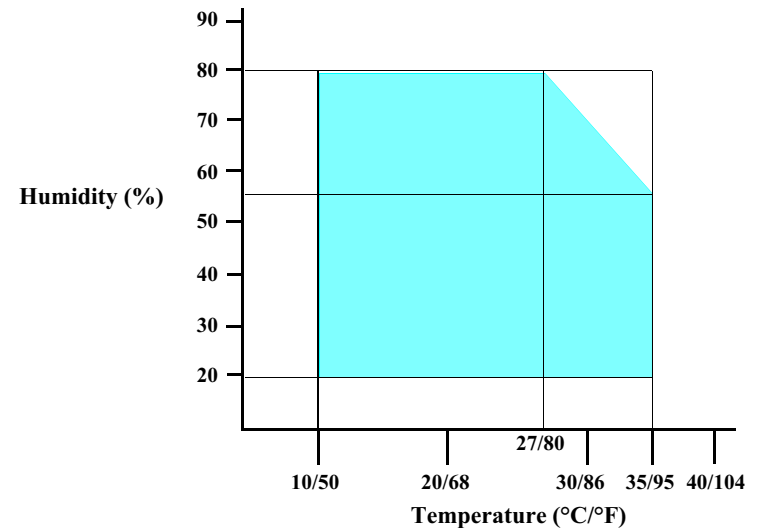

Figure 1-3. Temperature/Humidity Range



- When returning the repaired printer to the customer, make sure the Printhead is covered with the cap and the ink cartridge is installed.
- If the Printhead is not covered with the cap when the printer is off, turn on the printer with the ink cartridge installed, make sure the Printhead is covered with the cap, and then turn the printer off.

1.4.3 Durability

- Total print life: Black 16,000 pages (A4, 3.5% duty),
Color 10,000 pages (A4, 5% duty),
or five years which ever comes first
- Printhead: Six billions shots (per nozzle) or five years which ever comes first

1.4.4 Acoustic Noise

36 dB (when printing from PC, on Premium Glossy Photo Paper, in highest quality)

1.4.5 Safety Approvals (Safety standards/EMI)

USA	UL60950-1 FCC Part15 Subpart B Class B
Canada	CAN/CSA-C22.2 No.60950-1 CAN/CSA-CEI/IEC CISPR 22 Class B
Mexico	NOM-019-SCFI-1998
Taiwan	CNS13438 Class B CNS14336
EU	EN60950-1 EN55022 Class B EN61000-3-2, EN61000-3-3 EN55024
Germany	EN60950-1
Russia	GOST-R (IEC60950-1, CISPR 22)
Singapore	IEC60950-1
Korea	K60950-1 KN22 Class B KN61000-4-2/-3/-4/-5/-6/-11
China	GB4943 GB9254 Class B, GB17625.1
Argentina	IEC60950-1
Australia	AS/NZS CISPR22 Class B
Hong Kong	IEC60950-1

1.5 Operation Buttons & Indicators (LEDs)

1.5.1 Operation Buttons

The printer has the following three operation buttons.

Table 1-11. Operation Buttons

Button	Function
Power	Turns the power ON/OFF.
Ink	Runs a sequence of ink cartridge replacement or cleaning.
Paper	Feeds or ejects paper.

1.5.2 Indicators (LEDs)

Three indicators (LEDs) are provided to indicate settings or printer status.

Table 1-12. Indicators (LEDs)

LED	Function
Power LED (green)	Lights at power-on. Flashes during some sequence is in progress. Flashes at high speed during power-OFF sequence.
Ink LED (orange)* ¹	Lights or flashes when an ink-related error occurs.* ²
Paper LED (orange)* ¹	Lights or flashes when a paper- or CD-R-related error occurs.* ²

Note *1: The Ink LED and Paper LED stay OFF when printing from PC.

*2: See Table 1-15 “Indicators (LEDs) Function” for the LED status at error occurrence.

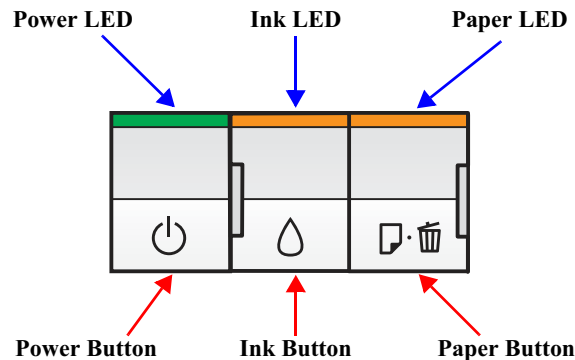

Figure 1-4. Buttons & LEDs

1.5.3 Operation Buttons & LEDs Functions

Detailed information on the buttons and LEDs functions are listed below.

Table 1-13. Operation Button Functions (During Normal Operation)

Button	Function
Power	• Turns the power ON/OFF
Ink	<ul style="list-style-type: none"> • Runs a sequence of ink cartridge replacement. The carriage moves to set the ink cartridge to the position for replacement. • Moves the carriage to set the ink cartridge to the ink check position when ink level low, ink out, or no ink cartridge error has occurred. • When an ink cartridge has been set in the ink check position, moves the carriage to set the cartridge to the position for replacement, or to set another cartridge to the ink check position. • When an ink cartridge has been set in the ink replacement position, moves the carriage to the home position.
Paper	<ul style="list-style-type: none"> • Feeds or ejects paper. • Recovers from a multi-feed error and feeds paper to restart the print job. • Feeds paper when paper is loaded after a no-paper error occurs. • Ejects a jammed paper when a paper jam error occurs. • Cancels the print job during printing.
Ink (when held for three seconds or longer)	<ul style="list-style-type: none"> • Runs a head cleaning. • Runs a sequence of ink cartridge replacement when ink level low, ink out, or no ink cartridge error has occurred.
Power + Paper * ¹ (combination)	• Prints a nozzle check pattern* ³ .
Power + Ink * ² (combination)	• Forcefully turns the power OFF.

Note 1: First press the Paper button and then Power button. The printer will turn On and print the nozzle check pattern.

2: First press the Power button and then Ink button. Hold them for seven seconds.

3: The nozzle check pattern printed by the printer is shown in Figure 1-5.

Table 1-14. Operation Button Functions (During CD-R Printing)

Button	CD-R Tray	Function
Paper	In	<ul style="list-style-type: none"> Recovers form a CD-R tray error. Cancels the print job during printing.
	Out	<ul style="list-style-type: none"> Recovers form a CD-R jam error.
Ink (including when held for three seconds or longer)	In	<ul style="list-style-type: none"> Does not function.
	Out	<ul style="list-style-type: none"> Same as during normal operation.

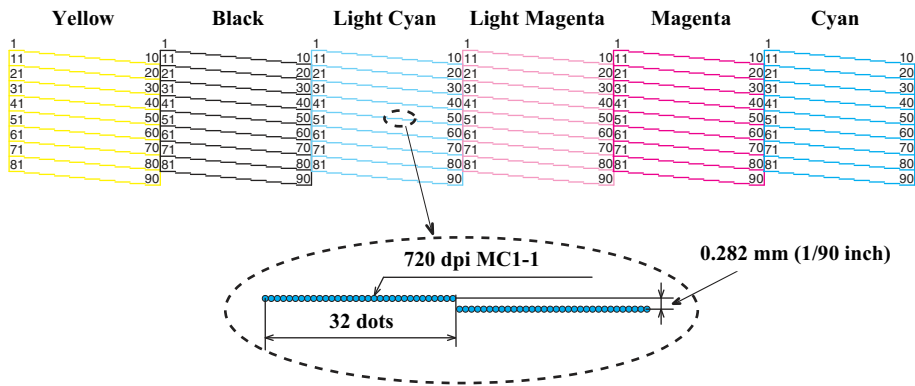

Note : The numbers shown in the figure are nozzle numbers. The numbers and color names are not printed on an actual nozzle check pattern.

Figure 1-5. Nozzle Check Pattern

Table 1-15. Indicators (LEDs) Function

Printer Status	Indicators (LEDs)			Priority*1
	Power	Ink	Paper	
Power OFF	Flashes at high speed	OFF	OFF	1
Fatal error	OFF	Flashes at high speed	Flashes at high speed	2
Maintenance request	OFF	Flashes alternately 2	Flashes alternately 1	3
CD-R guide error	--	Flashes at high speed	Flashes 2	4
Paper (CD-R) jam	--	--	Flashes	5
Multi-feed error	--	--	ON	6
No paper error	--	--	ON	6
CD-R Tray error	--	--	ON	6
Cover open error	--	Flashes 2	Flashes 2	6
Ink cartridge replacement is in progress	Flashes	--	--	7
Ink sequence is in progress	Flashes	--	--	8
CSIC error	--	ON	--	9
No ink cartridge error or ink-out error	--	ON	--	9
During feeding or ejecting paper	Flashes	--	--	10
Data processing	Flashes	--	--	10
Ink level low	--	Flashes	--	11
Power ON	ON	--	--	12
Reset request*2	ON	ON	ON	-

Note : --: No change
 Flash: Repeats turning On and Off every 1.25 seconds.
 Flash 2: Repeats On for 0.5 seconds, Off for 0.5 seconds, On for 0.5 seconds, and Off for 1.0 second.
 Flash at high speed: Repeats turning On and Off every 0.5 seconds.
 Flashes alternately 1: same as the "Flash"
 Flashes alternately 2: Repeats turning Off and On every 1.25 seconds.

Note *1: When two or more errors occur at the same time, the one with higher priority will be indicated.

*2: The all LEDs light for 0.2 seconds when a reset request is received.

1.5.4 Errors & Remedies

Table 1-16. Errors & Remedies

Error	Error	Remedies
Fatal error	A mechanical error has occurred.	Turn the power Off and back it On.
Maintenance request	Waste ink pads need to be replaced.	Replace the waste ink pads and reset the counter.
CD-R guide error	<ul style="list-style-type: none"> The CD-R guide (stacker) position does not match with the print job. The CD-R guide (stacker) is in the CD-R printing position at power-ON. 	Attach the CD-R guide (stacker) to the proper position.
Paper jam	A paper jam has occurred.	<p><When printing on paper> Remove the jammed paper and press the Paper button.*¹</p> <p><When printing on CD-R> Remove the jammed CD-R tray and press the Paper button.</p>
No paper	Failed to feed paper.	Load paper correctly and press the Paper button.* ¹
Multi-feed	Multiple sheets of paper were fed at the same time.	Press the Paper button to eject the multiple sheets.* ¹
CD-R Tray error	A CD-R tray were not detected.	Insert the CD-R tray and press the Paper button.
Ink-out	The cartridge has run out of ink.	Replace the ink cartridge.* ²
No ink cartridge Wrong ink cartridge	Ink cartridge(s) was not detected.	Replace the ink cartridge.* ²

Note : For more information on the remedies, see [3.2 Error Indications and Fault Occurrence Causes](#).

Note *1: When the CD-R guide (stacker) is attached to the upper position (CD-R print position), attach the guide to the lower position and press the Paper button.

*2: When the CD-R tray has been inserted, remove the CD-R tray and press the Ink button.

CHAPTER

2

OPERATING PRINCIPLES

2.1 Overview

This chapter describes the operating principles of the printer mechanism and electric circuit boards of Stylus Photo R280/R285/R290.

2.1.1 Printer Mechanism

The main components of the printer mechanism are shown in the table below.

Table 2-1. Printer Mechanism Main Components

Component	Function
CR Unit	Moves along the CR shaft to print on paper being powered by the CR motor. The unit includes Printhead, PW sensor, and CR encoder sensor.
APG Unit	Moves the carriage upward/downward to adjust the platen gap being powered by the PF motor. There are 4 preset levels of platen gap and the unit moves the carriage to one of the levels according to the current carriage position detected by the APG sensor.
PF Unit	Rotates the PF roller shaft to feed paper being powered by the PF motor.
ASF Unit	Being powered by the PF motor, feeds paper loaded on the ASF into the printer mechanism.
EJ Unit	Being powered by the PF motor, ejects paper or the CDR tray. The EJ frame moves corresponding to the stacker position so that the frame matches with the paper size.
Ink System	Located on the right side of the printer mechanism. Covers the printhead with the cap holder when the printhead is not used, and draws waste ink out of the printhead. The waste ink is sent to the Waste Ink Tray through the waste ink tube.

The main control boards are shown in the table below.

Table 2-2. Main Control Boards

Board	Function
Main Board	Located on top of the printer mechanism and controls all over the printer operations.
Power Supply Board (P/S ASSY)	Located on the Lower Housing and generates required voltages for the printer using the power supplied from the AC power line.
Panel Board	Located inside the Panel Unit and controls the operation panel.

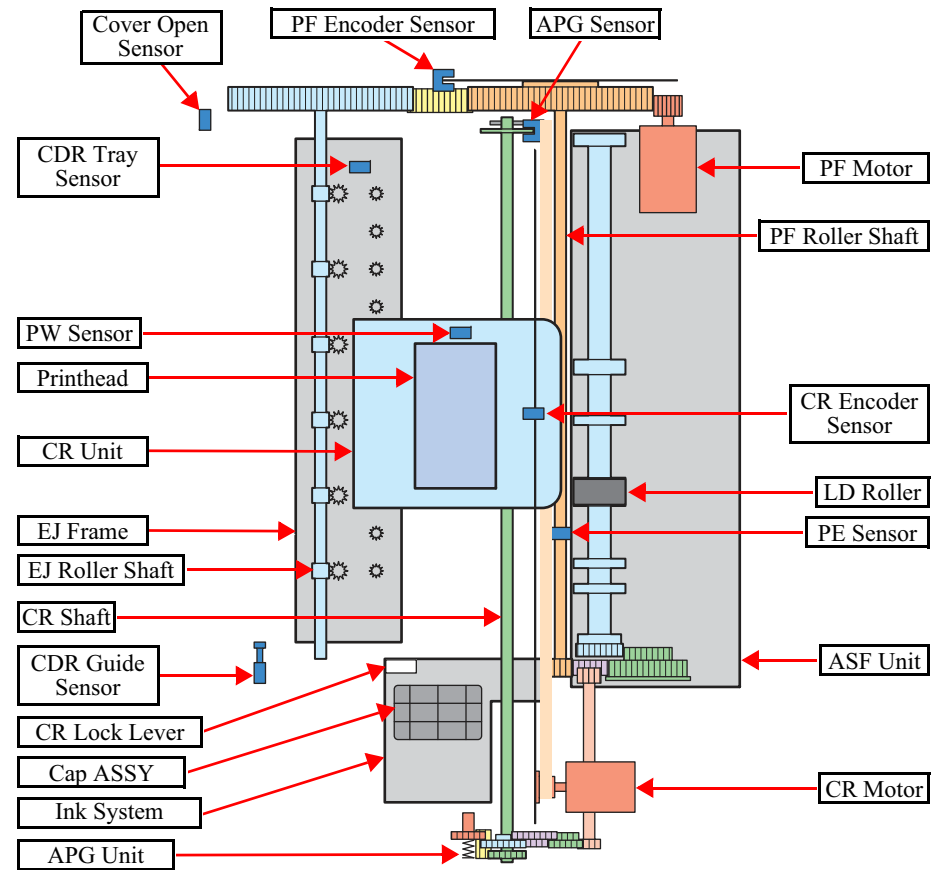

Figure 2-1. Printer Mechanism Diagram

2.1.2 Motors & Sensors

Table 2-3. List of Motors & Sensors

No.	Motor/Sensor Name	Function
1	Printhead	F3-MACH Turbo2 head (6 colors x 90 nozzles)
2	CR motor	Type: DC motor Drive voltage: 42V DC \pm 5% (voltage applied to the driver) Coil resistance: 22.7 Ω \pm 10% Inductance: 17.5mH \pm 25% Drive method: PWM constant-current chopping
3	PF motor	Type: DC motor Drive voltage: 42V DC \pm 5% (voltage applied to the driver) Coil resistance: 21.2 Ω \pm 10% Inductance: 17.2mH (1 kHz) Drive method: PWM
4	PE sensor	Detecting items: paper end, leading edge of paper Type: Transmissive photo interrupter
5	CR Contact module	Ink cartridge detection (CSIC)
6	CR Encoder sensor	Type: Transmissive photo interrupter Resolution: 180 pulse/inch
7	PF Encoder sensor	Type: Transmissive photo interrupter Resolution: 180 pulse/inch
8	PW sensor	Detecting items: • Left/right edges of paper (before/during printing) • Top edge of paper (before printing) • Bottom edge of paper (during printing) • Left/right/top/bottom of CDR (before printing) Type: Reflective photo interrupter
9	APG sensor	Detecting items: APG position Type: Transmissive photo interrupter
10	CDR Guide sensor	Detecting items: Up/Down status of the CDR Guide Type: Mechanical contact
11	CDR Tray sensor	Detecting items: Presence of CDR tray Type: Mechanical contact
12	Cover Open sensor	Detecting items: Open/Close status of the Printer Cover Type: Mechanical contact

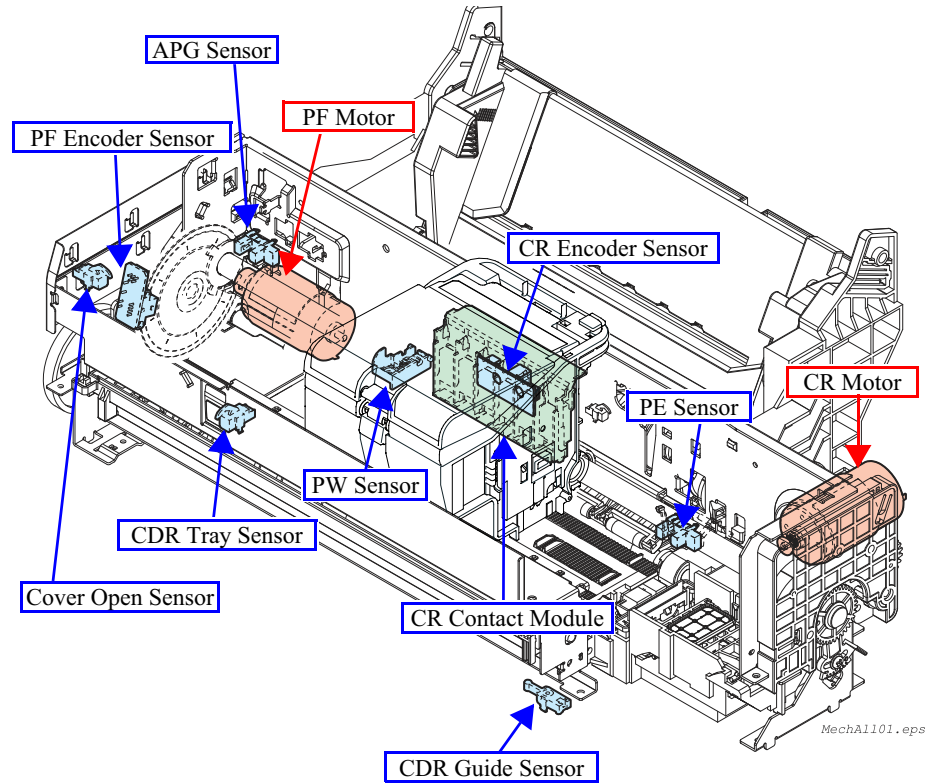

Figure 2-2. Motors & Sensors in the Printer Mechanism

2.2 Electrical Circuit Operating Principles

The electric circuits of the Stylus Photo R280/R285/R290 consist of the following boards.

Table 2-4. Main Boards & Model Numbers

Board Name	R280/R285/R290
Main Board	C691MAIN
Power Supply Board	C691PSB
Panel Board	C691PNL

2.2.1 Main Features

The circuits support multi-common printing method that achieves high-speed printing reducing the number of carriage movements.

- Features of C691Main Board
 - An EEPROM and a reset circuit are mounted individually to reduce the cost. This is achieved by removing a complex RTC circuit that is mounted on the previous model (R260/R265/R270/R360/R380/R390). Stylus Photo R280/R285/R290 do not need the complex RTC circuit because a backup timer is not required for them.
- Operations to reduce power consumption

The printer carries out the following operations to go into sleep mode.

 - Decreases the power voltage.
 - Shuts off photoelectric current of photo interrupter sensors.
 - Stops the motor drive circuit.
 - Stops some part of the clock in the ASIC.
 - De-energizes the motors.
 - Makes the head drive circuit go into standby state.

2.2.2 Components of Control Boards

Table 2-5. Components of Control Boards

Board Name		Incorporated Components
Main Board	System	<input type="checkbox"/> Logic circuit (SOC incorporated in the CPU core, Flash ROM (4 Mbit) x 1, SDRAM x 1, Local SDRAM controller, Local SDRAM (64 Mbit) <input type="checkbox"/> SSCG circuit <input type="checkbox"/> Panel I/F <input type="checkbox"/> Regulator <input type="checkbox"/> Power saver <input type="checkbox"/> Oscillator circuit <input type="checkbox"/> Power control circuit (PSC/ESAVE) <input type="checkbox"/> Reset circuit <input type="checkbox"/> USB interface <input type="checkbox"/> EEPROM
	Printer	<input type="checkbox"/> Motor drive circuit (PF, CR) <input type="checkbox"/> Printhead drive circuit <input type="checkbox"/> CSIC/IF <input type="checkbox"/> Sensor circuits
Panel Board		<input type="checkbox"/> Power switch read-in circuit <input type="checkbox"/> LED driving circuit

2.2.3 Circuit Block Diagram

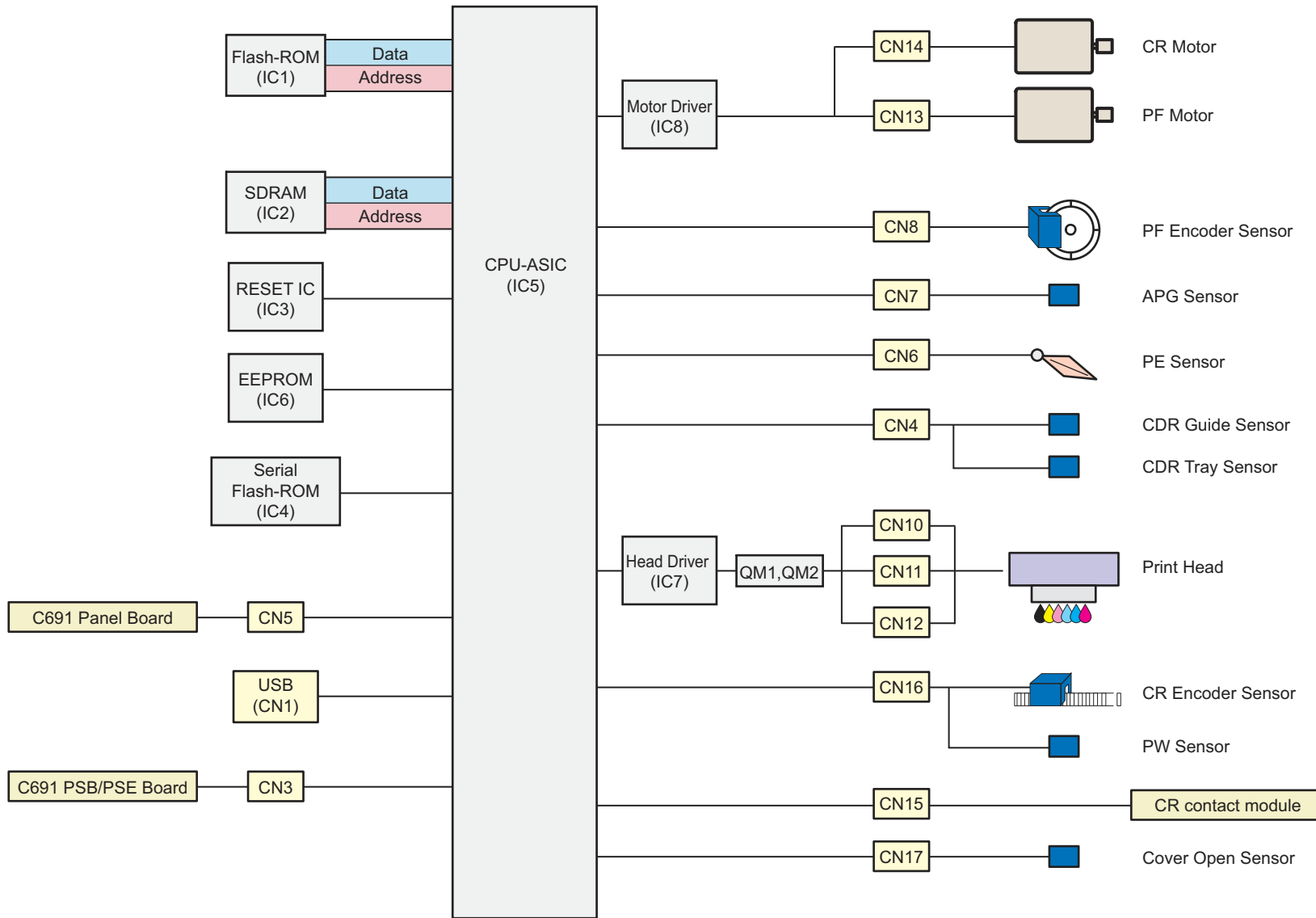

Figure 2-3. Circuit Block Diagram for R280/R285/R290

2.3 Banding Reduction System (BRS) / Paper Feed Amount Profile Correction (PFP)

□ Overview

In order to ensure high print quality and high print speed, this product incorporates the Banding Reduction System (BRS) and Paper Feed Profile (PFP) Correction system. The overview of them is described in the table below.

Table 2-6. Overview of BRS and PFP

	Summary	Target Print Mode			Remarks
		Paper Type	Paper Size	Resolutions (dpi)	
BRS	Conventional models perform overlapping printing (2-path or 4-path print) to reduce banding problem. Printers that incorporate the Banding Reducing System do not perform the overlapping printing. They carry out 1-path printing correcting ink drop amount for each raster mode in order to avoid making a gap between each path (printed line). This enables to achieve both high print quality (less banding) and high print speed.	Ultra Glossy Photo Paper Premium Glossy Photo Paper Glossy Photo Paper Premium Semigloss Photo Paper	4 x 6 inch (102 x 152 mm)	720 x 720	---
PFP	In the conventional method to improve paper feed accuracy, the adjustment value is calculated based on a value obtained at a certain point of paper. Therefore, correcting the total paper feed amount (from when paper is fed and to when finishing printing) was impossible. The Paper Feed Amount Profile Correction offers more precise control over the paper feeding. Paper feed errors are measured at various points and a correction value is calculated for each of the points. This enables to ensure print quality in the target print mode.	Ultra Glossy Photo Paper Premium Glossy Photo Paper Glossy Photo Paper Premium Semigloss Photo Paper	4 x 6 inch (102 x 152 mm)	720 x 720	With BRS, Borderless print
				720 x 360	Without BRS, Borderless print

□ Adjustment/Correction method

Correction values of the BRS and the PFP are automatically calculated when a pattern printed by the printer is scanned by a specified scanner. The created correction values are stored into the serial flash ROM on the main board, and applied when printing in the target print mode.



For information on how to carry out the BRS and PFP, See [Chapter 5 Adjustment](#).

TROUBLESHOOTING

CHAPTER

3

3.1 Overview

This chapter provides how to troubleshoot problems analyzing the cause based on the messages shown by the printer driver, printer’s LED status and the observed symptom. Identify and troubleshoot the problem referring to the tables on the following pages. When some parts need to be replaced, make sure to follow the procedure given in Chapter 4 and carry out required adjustments. If any abnormality is observed in motors or sensors, check the electrical value referring to the 3.1.1 “Troubleshooting on Motors and Sensors”(p.28).

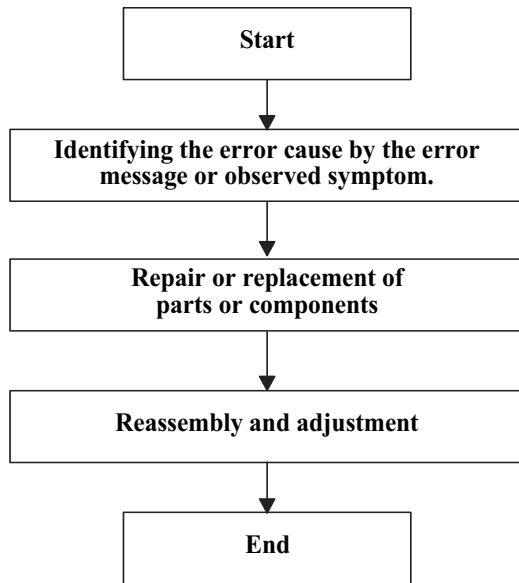

Figure 3-1. Troubleshooting Flowchart

3.1.1 Troubleshooting on Motors and Sensors

The following tables show the normal electric values of each motor and sensor. When any abnormality is observed in motors and sensors, check their electric values and compare them with the values given in the tables to see if the motors or sensors are broken or not.

Table 3-1. Motor Resistance & Measuring Points

Motor	Motor Connector	Measuring Points	Resistance
CR Motor	CN14	Between Pin 1 and 2	22.7Ω ± 10%
PF Motor	CN13	Between Pin 1 and 2	21.2Ω ± 10%

Table 3-2. Sensor Checkpoints

Sensor	Sensor Connector	Signal Level	Status
PE Sensor	CN6 Between Pin 1 and 2	2.4V or more	No paper
		0.4V or less	Paper exists
APG Sensor	CN7 Between Pin 1 and 2	2.4V or more	Within PG position
		0.4V or less	Out of PG position
CDR Guide Sensor	CN4 Between Pin 1 and 2	Open: 2.4V or more	CDR mode (Stacker is at the upper position)
		Close: 0.4V or less	ASF mode (Stacker is at the lower position)
CD-R Tray Sensor	CN4 Between Pin 3 and 4	Open: 2.4V or more	CD-R Tray inserted
		Close: 0.4V or less	No CD-R Tray
Cover OPEN Sensor	CN17 Between Pin 1 and 2	Open: 2.4V or more	Printer Cover opened
		Close: 0.4V or less	Printer Cover closed

Note : See 2.1.2 “Motors & Sensors”(p.23) for locations of the motors and sensors.

3.2 Warning / Error Indications

This section describes how the printer indicates an error/warning status with LEDs, or on the screen of the printer driver when a problem arises during various operations; power-on sequence, paper feeding, ink drawing, printing, and so on.

3.2.1 Error Indication Method

The Stylus Photo R280/R285/R290 are equipped with LEDs. You can check most of the troubles with the status of the LEDs or messages shown on the windows of “EPSON Status Monitor 3”. (See 1.5.3 “Operation Buttons & LEDs Functions”(p.18))

LEDs Status

LED Status	Meaning
--	No change
Light	Lights up normally
Flash	Flashes at intervals of 1.25 seconds.
Flash 2	Flashes as follows; ON (0.5 sec.) - OFF (0.5 sec.) - ON (0.5 sec.) - OFF (1.0 sec.)
Flashes at high speed	Flashes at intervals of 0.5 seconds.
Flashes Alternatively 1	Same as Flash
Flashes Alternatively 2	Flashes at intervals of 1.25 seconds.

Message box on the window of “EPSON Status Monitor 3”

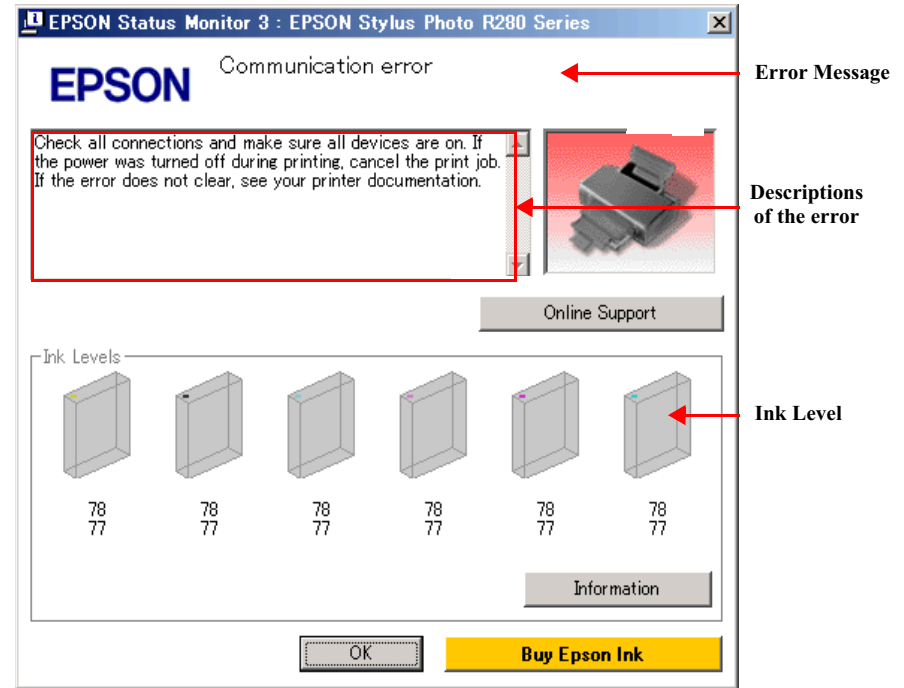

Figure 3-2. Error Indication on EPSON Status Monitor 3

NOTE: The part number of the Ink Cartridges shown in the Status Monitor 3 screen differs by destination.

Table 3-3. List of Error Messages

Error Name	LED Indications			STM3 Message	Error Cause	See the table for Troubleshooting
	Power	Ink	Paper			
Communication error	-	-	-	Check all connections and make sure all devices are on. If the power was turned off during printing, cancel the print job. If the error does not clear, see your printer documentation.	The printer cannot communicate with the PC properly.	Table 3-4 (p.31)
Fatal error	Off	Flashes at high speed	Flashes at high speed	Delete all print jobs and turn the printer off. Remove any foreign objects from inside the printer. After a few minutes, turn the printer back on.	A mechanical error has occurred.	Table 3-5 (p.32)
Maintenance request error	Off	Flashes alternately 2	Flashes alternately 1	Parts inside your printer are at the end of their service life. See your printer documentation.	Waste ink pads need to be replaced.	-
CDR Guide error	-	Flashes at high speed	Flash 2	For sheets of paper, manually set the front tray in the lower paper position. For a CD or DVD, manually set the front tray in the upper CD/DVD position.	<ul style="list-style-type: none"> The CD-R guide (stacker) position does not match with the print job. The CD-R guide (stacker) is in the CD-R printing position at power-ON. 	Table 3-11 (p.41)
Paper (CDR) jam	-	-	Flash	For sheets of paper, turn off the printer and then remove any jammed paper by hand. For a CD or DVD, remove the CDR tray. Next, press the Paper button on the printer or click the Eject button if it appears on this screen.	A paper jam has occurred.	Table 3-8 (p.36)
No paper	-	-	Light	Reload the paper and manually set the front tray in the lower paper position. Then press the Paper button on the printer or click the Continue button if it appears on the screen. To cancel all print jobs, click the Cancel button.	Failed to feed paper.	Table 3-9 (p.38)
Multi-feed	-	-	Light	A page has not been printed, multiple pages have been fed into the printer at once, or the wrong paper size has been fed into the printer. Remove and reload the paper. Press the Paper button if necessary.	Multiple sheets of paper were fed at the same time.	Table 3-8 (p.36)
CDR Tray error	-	-	Light	Reload the tray, then press the Paper button on the printer.	A CD-R tray was not detected.	Table 3-10 (p.40)
Ink-out	-	Light	-	Black: XXXX*	The cartridge has run out of ink.	Table 3-7 (p.35)
No ink cartridge	-	Light	-	Color: XXXX*		
Wrong ink cartridge	-	Light	- Epson recommends the genuine Epson cartridges listed above. Click the How to button for ink cartridge replacement instructions.		
Cover open error	-	Flash 2	Flash 2	Close the printer cover.	The Cover Open Sensor detects the Printer Cover is open.	Table 3-6 (p.34)

Note *: The “XXXX” represents the part number of the Ink Cartridge.

3.3 Troubleshooting by Error Message

The following tables provide troubleshooting procedure for each error indicated by the LEDs or STM3 screen. When some parts need to be replaced or repaired, make sure to follow the procedure given in Chapter 4 and carry out required adjustments.

3.3.1 Troubleshooting Problems with Error Messages

Table 3-4. Troubleshooting for Communication Error

Occurrence Timing	Symptom	Failed Part	Check Point	Remedy	Reference
At power-on	The printer does not work at all.	Panel Board/ Panel FFC	1. Is the Panel FFC not connected to the Panel Board and CN5 on the Main Board?	1. Connect the FFC correctly.	4.3.2 "Panel Assy/ Cover Open Sensor"(p.64)
			2. Is the Panel FFC damaged?	2. Replace the Panel FFC.	
			3. Is the Panel Board damaged?	3. Replace the Panel Board.	
		P/S ASSY	1. Is the P/S ASSY connector cable not connected to CN3 on the Main Board?	1. Connect the cable correctly.	4.3.3 "P/S Assy"(p.68)
			2. Is the P/S ASSY cable or the P/S ASSY itself damaged?	2. Replace the P/S ASSY. * If this does not solve the problem, replace the Main Board Assy.	
		USB cable	1. Is the USB cable not connected to the printer and the PC?	1. Connect the USB cable correctly.	-
Printer driver	1. The printer driver installed on the PC is not the one for the Stylus Photo R280/R285/R290?	1. Install the correct printer driver.	-		
Main Board	1. The model name written into EEPROM on the Main Board is wrong?	1. Write the correct model name to the EEPROM using the Adjustment Program.	5.1.1 "Servicing Adjustment Item List" (P.96)		

Table 3-5. Troubleshooting for Fatal Error

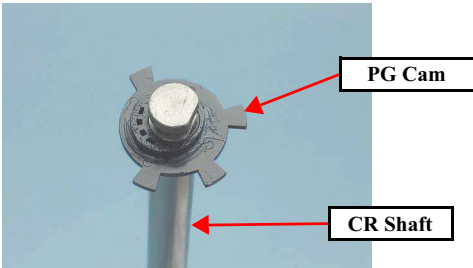
Occurrence Timing	Symptom	Failed Part	Check Point	Remedy	Reference	
At power-on	<ul style="list-style-type: none"> CR motor does not rotate at all. CR Unit hits against the right side of the Main Frame. 	CR Motor	1. Is the CR motor cable not connected to CN14 on the Main Board?	1. Connect the cable correctly.	4.3.1 "Main Board Unit"(p.61)	
			2. Is there a malfunction of the CR motor?	2. Replace the CR motor.	4.4.12 "CR Motor"(p.84)	
		Main Frame	1. Is there any dirt on the Main Frame? Or is the frame not adequately lubricated?	1. Clean off any dirt on the frame and apply adequate grease on it.	6.1.3 "Lubrication" (P.114)	
		CR Guide Shaft	1. Is there any dirt on the CR Guide Shaft? Or is the shaft not adequately lubricated?	1. Clean off any dirt on the shaft and apply adequate grease on it.		6.1.3 "Lubrication" (P.114)
			2. Is the PG cam chipped or broken?	2. Replace the CR Guide Shaft.		
		CR Encoder	1. Is the Head FFC not connected to the CR encoder connector?	1. Connect the Head FFC to the connector correctly.	4.4.13 "CR Unit"(p.86)	
			2. Is the CR encoder chipped or broken?	2. Replace the CR Unit.		
		Head FFC	1. Is the Head FFC broken?	1. Replace the Head FFC.		
		CR Scale	1. Is the CR Scale not moving freely, centered between the sides of CR encoder sensor?	1. Install the CR Scale correctly.	4.4.3 "CR Scale"(p.74)	
			2. Is there any dirt on the CR Scale?	2. Clean off any dirt on the CR Scale. If the scale get heavily soiled, replace the scale.		
			3. Is the CR Scale chipped or broken?	3. Replace the CR Scale.		
		Timing Belt	1. Is the Timing Belt attached incorrectly?	1. Attach the belt correctly.	4.4.13 "CR Unit"(p.86) / 4.4.12 "CR Motor"(p.84)	

DURAKLIN

Table 3-5. Troubleshooting for Fatal Error

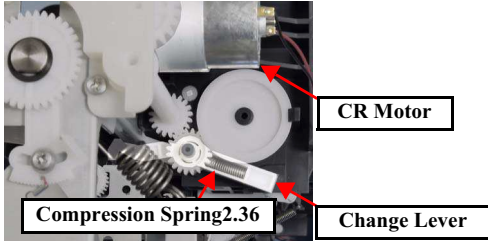
Occurrence Timing	Symptom	Failed Part	Check Point	Remedy	Reference
At power-on	<ul style="list-style-type: none"> The CR Unit hits against the Change Lever which has come down toward the front of the printer. The error appears after the PF roller makes quick one-turn. 	ASF Unit	1. Is the Compression spring 2.36 of the Change Lever disengaged? 	1. Replace the ASF Unit.	4.4.14 "ASF Unit"(p.88)
		PF Motor	1. Is the PF motor cable not connected to CN13 on the Main Board?	1. Connect the cable to the Main Board.	4.3.1 "Main Board Unit"(p.61)
			2. Is there a malfunction of the PF motor?	2. Replace the PF motor.	4.4.11 "PF Motor"(p.83)
		PF Encoder	1. Is the PF encoder FFC not connected to the PF encoder connector and the Main Board?	1. Connect the FFC to the PF encoder and the Main Board.	4.3.1 "Main Board Unit"(p.61)
			2. Is the PF encoder chipped or broken?	2. Replace the PF encoder.	4.4.10 "PF Encoder / PF Scale"(p.83)
		PF Scale	1. Is the PF Scale not moving freely, centered between the sides of PF encoder sensor?	1. Install the PF Scale or PF encoder correctly.	4.4.10 "PF Encoder / PF Scale"(p.83)
			2. Is there any dirt on the PF Scale?	2. Clean off any dirt on the PF Scale. If the scale gets heavily soiled, replace the scale.	4.4.10 "PF Encoder / PF Scale"(p.83)
	3. Is the PF Scale chipped or broken?		3. Replace the PF Scale.		
	The CR Unit hits against the Upper Paper Guide detached from the Main Frame.	Upper Paper Guide	1. Is the Upper Paper Guide detached from the Main Frame?	1. Attach the Upper Paper Guide correctly.	4.4.15 "Upper Paper Guide"(p.90)

DURAKLIN

Table 3-5. Troubleshooting for Fatal Error

Occurrence Timing	Symptom	Failed Part	Check Point	Remedy	Reference
At power-on During changing the platen gap	The error occurs when the PG (gap between the printhead surface and the platen) is changed with the APG Unit.	APG Unit	1. Is the APG Unit installed incorrectly?	1. Install the APG Unit carefully so as not to shift the phase.	4.4.4 “APG Unit”(p.75)
			2. Is the Combination Gear 10,15.2 disengaged or attached incorrectly?	2. Attach the gear correctly.	
					
		APG Sensor Assy	1. Is the APG sensor damaged?	1. Replace the APG Sensor Assy.	4.4.16 “APG Sensor Assy”(p.91)
Any time	Other than above symptoms	Printhead	1. Is the Printhead damaged?	1. Replace the Printhead.	4.4.2 “Printhead”(p.72)
		Main Board	1. Is the Main Board damaged?	1. Replace the Main Board.	4.3.1 “Main Board Unit”(p.61)

Table 3-6. Troubleshooting for Cover Open Error

Occurrence Timing	Symptom	Failed Part	Check Point	Remedy	Reference
At power-on	The Printer Cover is closed, but the Cover Open error occurs.	Cover Open Sensor	1. Is the Cover Open Sensor cable not connected to CN17 on the Main Board?	1. Connect the cable to the connector on the Main Board.	4.3.2 “Panel Assy/ Cover Open Sensor”(p.64)
			2. Is the Cover Open Sensor cable damaged?	2. Replace the Cover Open Sensor cable.	
			3. Is the Cover Open Sensor damaged?	3. Replace the Cover Open Sensor.	

Table 3-7. Troubleshooting for Ink Cartridge Detection Error/ Ink Cover Open Error/ Cartridge Empty Error

Occurrence Timing	Symptom	Failed Part	Check Point	Remedy	Reference
At power-on	The error appears after the carriage home position is detected.	Ink Cartridge	1. Is the memory chip on the cartridge chipped or broken? 	1. Replace the ink cartridge.	-
		Head FFC	1. Is the Head FFC not connected to the Head Board and CN10, CN11, and CN12 on the Main Board?	1. Connect the Head FFC to the Head Board and the Main Board.	4.4.13 “CR Unit”(p.86) / 4.3.1 “Main Board Unit”(p.61)
		Head Board	1. Are the CSIC terminals chipped or broken?  2. Is the Head Board damaged? 	1. Replace the CSIC ASSY. 2. Replace the CSIC ASSY.	4.4.2 “Printhead”(p.72)

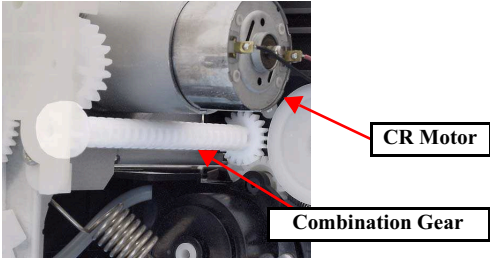
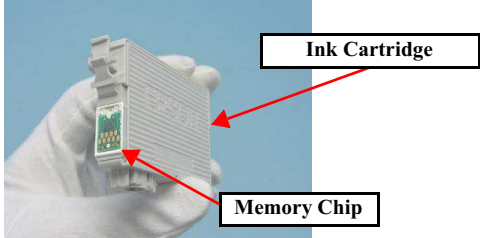
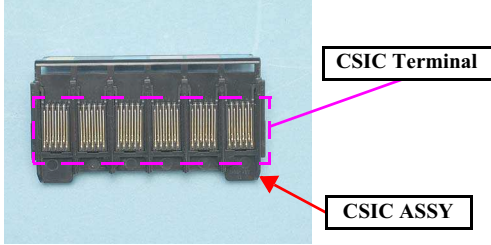
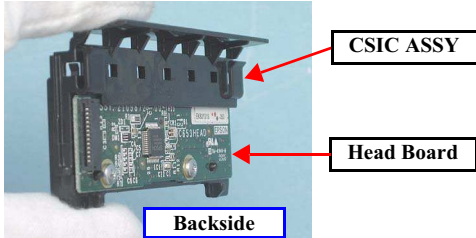
DURAKLIN

Table 3-8. Troubleshooting for Paper Jam Error

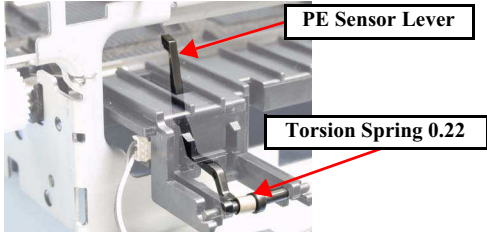
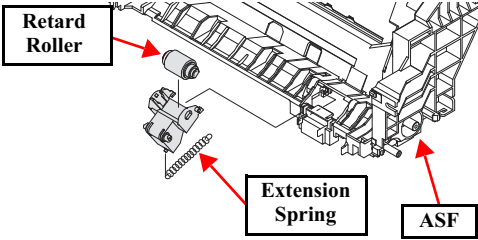
Occurrence Timing	Symptom	Failed Part	Check Point	Remedy	Reference
Any time	Even though the printer performs paper feeding operation, the paper is not fed into the printer.	ASF Unit	1. Is the ASF Unit installed incorrectly? 2. Is the Paper Return Lever not moving properly during the feeding operation?	1. Install the ASF Unit correctly. 2. Install the Paper Return Lever and the Torsion Spring 6.45 correctly.	4.4.14 "ASF Unit"(p.88)
		Front Paper Guide Assy	1. Is the Torsion Spring 0.22 attached incorrectly? 	1. Install the PE Sensor Lever and Torsion Spring 0.22 correctly.	4.4.17 "Front Paper Guide Assy"(p.92)
	Multiple sheets are fed at a time.	ASF Unit	1. Is the Retard Roller Assy not moving properly during the feeding operation? 	1. Attach the Extension Spring 1.98 on the back side of the Retard Roller Assy correctly.	4.4.14 "ASF Unit"(p.88)
Paper is fed into the printer, but ejected at once without any printing operation.		PE Sensor	1. Is the PE sensor cable not connected to CN6 on the Main Board?	1. Connect the cable to the Main Board.	4.3.1 "Main Board Unit"(p.61)
			1. Is the PE Sensor damaged?	2. Replace the PE Sensor.	4.4.17 "Front Paper Guide Assy"(p.92)

DURAKLIN

Table 3-8. Troubleshooting for Paper Jam Error

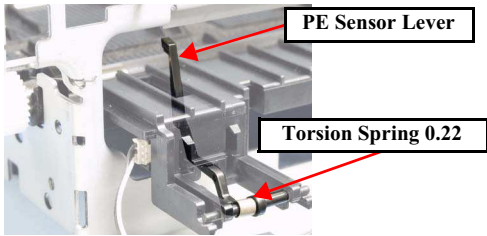
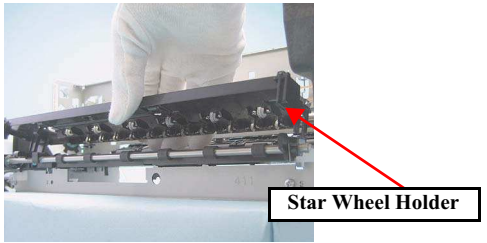
Occurrence Timing	Symptom	Failed Part	Check Point	Remedy	Reference
Any time	Paper is fed into the printer, but ejected at once without any printing operation.	PE Sensor	3. Is the Torsion Spring 0.22 detached or attached incorrectly?	3. Install the PE Sensor Lever and the Torsion Spring 0.22 correctly.	4.4.17 “Front Paper Guide Assy”(p.92)
					
	Paper cannot go through between the EJ Roller and the Star Wheel Roller.	Front Paper Guide Pad	1. Is the Front Paper Guide Pad attached incorrectly?	1. Install the pad correctly.	4.4.9 “EJ Frame Assy”(p.80)
		EJ Frame ASSY*	1. Is the Star Wheel Holder detached?	1. Attach the Star Wheel Holder correctly.	
			2. Is the EJ Frame Assy installed incorrectly?	2. Install the EJ Frame Assy correctly.	
		3. Has the EJ Frame Assy become deformed obstructing the paper path?	3. Replace the EJ Frame Assy.		
	The leading edge of paper does not reach the PF Roller.	Upper Paper Guide*	1. Is the Upper Paper Guide disengaged from the Main Frame?	1. Install the Upper Paper Guide correctly.	4.4.15 “Upper Paper Guide”(p.90)

Note : * Be careful not to let jammed paper rub against the nozzle surface of the Printhead, or it may damage the Printhead.

Table 3-9. Troubleshooting for No Paper Error

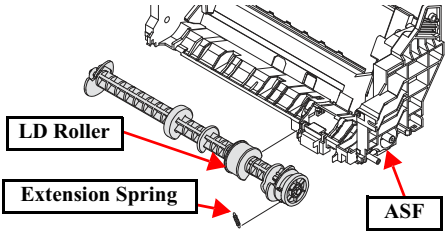
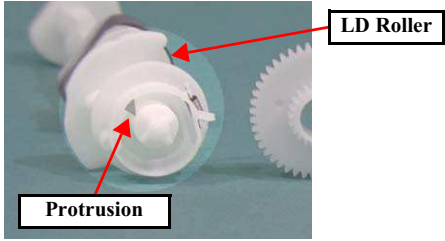
Occurrence Timing	Symptom	Failed Part	Check Point	Remedy	Reference
Any time	The LD Roller rotates normally to feed paper, but the Hopper does not move.	ASF Unit	1. Is the Hopper not moving properly during the feeding operation?	1. Attach the Compression Spring 2.51 correctly to the ASF Frame and the Hopper.	4.4.14 “ASF Unit”(p.88)
	The LD Roller rotates normally, but paper is not fed into the printer.	ASF Unit	1. Is there any paper dust on the LD Roller?	1. Remove the paper dust on the LD Roller with a cloth moistened with alcohol. * If this does not solve the problem, replace the ASF Unit.	
	The PF Motor drive force is not transmitted to the LD Roller shaft.	ASF Unit	1. Is the Extension Spring 0.143 of the clutch mechanism detached?  2. Is the protrusion of the clutch chipped or broken? 	1. Attach the Extension Spring 0.143 correctly. 2. Replace the ASF Unit.	

DURAKLIN

Table 3-9. Troubleshooting for No Paper Error

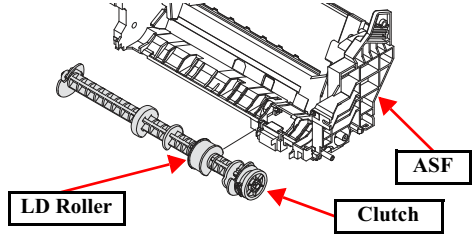
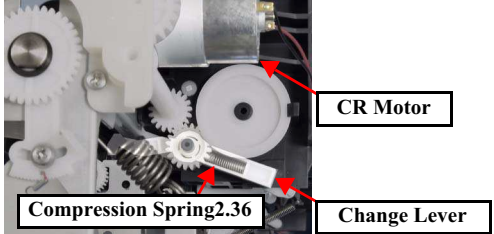
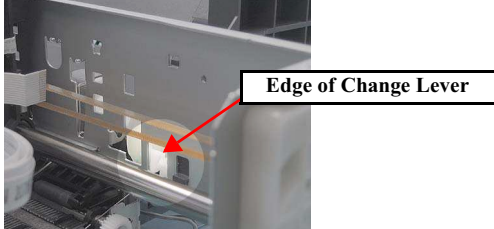
Occurrence Timing	Symptom	Failed Part	Check Point	Remedy	Reference
Any time	The PF Motor drive force is not transmitted to the LD Roller.	ASF Unit	3. Is the clutch damaged? 	3. Replace the ASF Unit.	4.4.14 “ASF Unit”(p.88)
	The LD Roller shaft is not set in the ASF home position, and paper is always fed from the ASF Assy.	ASF Unit	4. Is the Compression Spring 2.36 of the Change Lever detached? 	4. Replace the ASF Unit.	
			1. Is the edge of the Change Lever chipped or broken? 	1. Replace the ASF Unit.	

DURAKLIN

Table 3-10. Troubleshooting for CD-R Tray Error

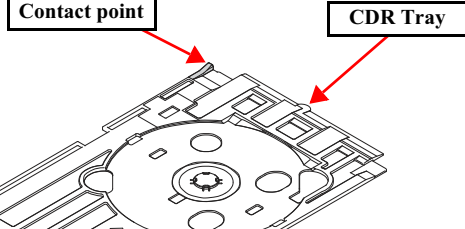
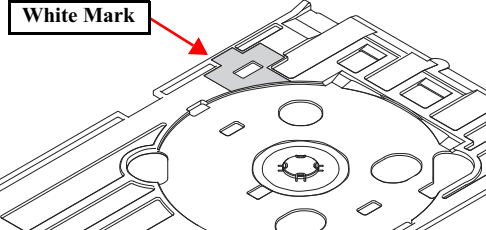
Occurrence Timing	Symptom	Failed Part	Check Point	Remedy	Reference
When printing on CDs/DVDs	The CDR Tray is set to the printer, but the error occurs.	CDR Tray	1. Has the part of the CDR Tray that contacts with the CDR Tray Sensor become cracked? 	1. Replace the CDR Tray.	-
		CDR Tray Sensor	1. Is the CDR Sensor cable not connected to CN4 on the Main Board? 2. Is the CDR Tray Sensor damaged?	1. Connect the cable to the connector on the Main Board. 2. Replace the CDR Tray Sensor.	4.4.18 “CDR Tray Sensor”(p.94) / 4.3.1 “Main Board Unit”(p.61)
		CDR Tray	1. Is there any paper dust or foreign matter on the white mark on the CDR Tray? 	1. Remove any dust or foreign matter from the tray.	-

DURAKLIN

Table 3-10. Troubleshooting for CD-R Tray Error

Occurrence Timing	Symptom	Failed Part	Check Point	Remedy	Reference	
When printing on CDs/DVDs	The CDR Tray center detection sequence is interrupted, and the tray is ejected.	PW Sensor	1. Is there any paper dust or ink stain on the PW Sensor?	1. Clean off any dirt on the PW Sensor.	4.4.13 “CR Unit”(p.86)	
						
			2. Is the PW Sensor cable not connected to the CR Encoder Board and the PW Sensor?	2. Connect the PW Sensor cable to the CR Encoder Board and the PW Sensor.		
			3. Is the PW Sensor cable broken?	3. Replace the CR Unit.		4.4.13 “CR Unit”(p.86)
		4. Is the PW Sensor damaged?	4. Replace the CR Unit.			
		Main Board	1. Is there any chipped or broken elements on the Main Board?	1. Replace the Main Board.	4.3.1 “Main Board Unit”(p.61)	

Table 3-11. Troubleshooting for CDR Guide Error

Occurrence Timing	Symptom	Failed Part	Check Point	Remedy	Reference
When printing on CDs/DVDs	The CDR Guide is set correctly, but the error occurs.	CDR Sensor	1. Is the CDR Guide Sensor cable not connected to CN4 on the Main Board?	1. Connect the cable to the cable on the Main Board.	4.3.1 “Main Board Unit”(p.61)
			2. Is the CDR Guide Sensor damaged?	2. Replace the CDR Guide Sensor.	4.4.7 “Left & Right Guide Stackers / CDR Guide Sensor”(p.78)
			3. Is the CDR Guide Sensor cable broken?	3. Replace the CDR Guide Sensor cable.	
				Main Board	1. Is there any chipped or broken elements on the Main Board?

3.4 Troubleshooting by Symptom

3.4.1 Problems in Printing Operation

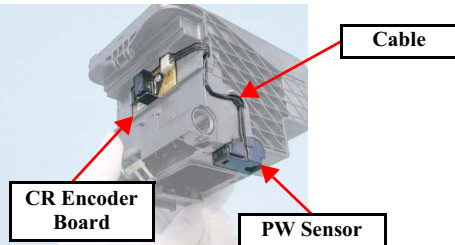
This section provides how to troubleshoot the possible problems on the printer mechanism. No error message appears for most of the troubles described here. In the following tables, find the symptom you face and follow the troubleshooting procedure given in the table.

Paper Feeding Problems

Table 3-12. Troubleshooting Paper Feeding Problems

Symptom	Possible Cause	Check Point	Remedy
Paper is not fed into the printer.	The LD Roller is contaminated or worn-out	Is there any "micro pearl" paper dust or oil stain on the LD Roller?	Use a cleaning sheet in order to clean the rollers. 1. Set a cleaning sheet in the ASF turning the sheet upside down. 2. Press the button on the operation panel to load the sheet. 3. Repeat the above procedure several times.
			In order to remove a severe smear, staple a cloth moistened with alcohol to a post card and carry out the following operations. 1. Set the post card in the ASF with the attached cloth facing the LD Roller or Retard Roller. 2. Then, holding the top edge, press the button on the operation panel to load the card. 3. Repeat Step 2. The paper dust or oil stain on the LD Roller or the Retard Roller surface is removed. If this does not solve the problem, replace the LD or Retard Roller.
	The Pickup Roller and Idle Roller are contaminated or worn-out	Is there any "micro pearl" paper dust or oil stain on the Pickup and Idle Rollers?	Wipe the roller surface with a cloth moistened with alcohol.
	Malfunction of the Paper Feed Mechanism	Is there a malfunction of the Paper Feeding Mechanism?	<input type="checkbox"/> Correct the phases of the Paper Feed Mechanism. <input type="checkbox"/> Remove any dust or foreign matter in the Paper Feed Mechanism.
	Malfunction of the PE Sensor and PE Lever	Is the PE Sensor connector disconnected from the Main Board or the sensor?	Connect the PE Sensor cable to CN6 on the Main Board and the PE Sensor correctly.
Is the Torsion Spring 0.22 detached or attached incorrectly?		Attach the Torsion Spring 0.22 and the PE Lever correctly.	
			
	Is the PE Sensor damaged?	Replace the PE Sensor.	

Table 3-12. Troubleshooting Paper Feeding Problems

Symptom	Possible Cause	Check Point	Remedy
Multiple sheets are fed at a time.	A malfunction of the Retard Roller	Is the Extension Spring 1.98 at backside of the Retard Roller detached?	Attach the Extension Spring correctly.
			
		Is the Retard Roller detached?	Install the Retard Roller correctly.

Problems with ejecting paper

Table 3-13. Troubleshooting Paper Ejecting Problems

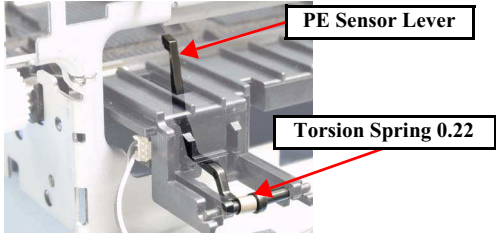
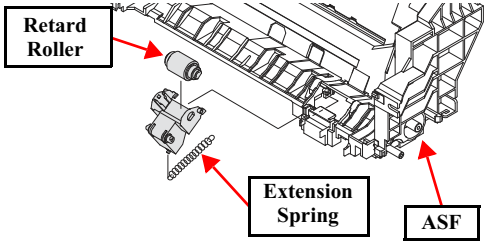
Symptom	Possible Cause	Check Point	Remedy
Paper jam occurs during ejecting paper.	A malfunction of paper feeding mechanism	Is the PF Roller not moving correctly without its drive force transmitted to the EJ Roller?	Engage the gears in the paper feed mechanism correctly.
	A malfunction of EJ Roller	Is the EJ Roller moving correctly?	Engage the gears which transmit drive force to the EJ Roller.

Problems with carriage (CR Unit) movements

Table 3-14. Troubleshooting Carriage Movement Problems

Symptom	Possible Cause	Check Point	Remedy
Movements of the CR Unit during printing is abnormal.	Something interferes with the operation of the CR Unit.	Is there any obstruction on the carriage path?	Remove the obstruction.
		Move the CR Unit with your hand. The unit does not move smoothly?	Clean the CR shaft and apply grease.
		Is the slack of the Head FFC not enough or too much interfering the carriage movement? Check that by moving the carriage from side to side with your hand.	Route the Head FFC around the Main Frame correctly.

❑ Printer initialization operation is aborted

Table 3-15. Troubleshooting Initialization Stop Problems

Symptom	Possible Cause	Check Point	Remedy
An error occurs during initialization after power-on	Improper installation of the EJ Frame	Are the tabs of the EJ Frame disengaged?	Reinstall the EJ Frame correctly.
	A malfunction of the CR Motor	Is the CR Motor cable/connector disconnected?	Connect the CR Motor cable to CN14 on the Main Board.
	A malfunction of the PF Motor	Is the PF Motor cable/connector disconnected?	Connect the CR Motor cable to CN13 on the Main Board.
	CR linear Scale failure	Is the CR Linear Scale not moving freely, centered between the sides of CR encoder sensor?	Install the scale correctly.
		Is there any dirt on the CR Linear Scale?	Clean off any dirt on the scale.3
		Is the CR Linear Scale chipped or broken?	Replace the CR Linear Scale.
	A malfunction of the CR Encoder	Is the Encoder FFC disconnected from the CR Encoder Board?	Connect the FFC to the board properly.
		Is there any paper dust or dirt on the CR Encoder?	Remove any paper dust or dirt on the CR Encoder.
		Is the Encoder FFC damaged or broken?	Replace the Head FFC.
		Is the CR Encoder damaged or broken?	Replace the CR Unit.
	PF Scale failure	Is the PF Scale not moving freely, centered between the sides of PF encoder sensor?	Install the scale correctly.
		Is there any dirt on the PF Scale?	Clean off any dirt on the scale.
		Is the PF Scale chipped or broken?	Replace the PF Scale.
	A malfunction of the PF Encoder	Is the Encoder FFC disconnected from the PF Encoder Board?	Connect the FFC to the board properly.
		Is there any paper dust or dirt on the PF Encoder?	Remove any paper dust or dirt on the PF Encoder.
		Is the Encoder FFC broken?	Replace the Encoder FFC.
		Is the PF Encoder damaged or broken?	Replace the PF Encoder.
	Head FFC failure	Is the Head FFC disconnected?	Connect the FFC to CN10, CN11, CN12, CN15, and CN16 on the Main Board.
		Is the Head FFC damaged or broken?	Replace the Head FFC.
	Printhead failure	Are the all nozzles not firing ink properly?	Replace the Printhead.

DURAKLIN

- Print quality problems

Table 3-16. Troubleshooting Print Quality Problems

Symptom	Possible Cause	Check Point	Remedy
Printed image has missing colors, and the missed colors are always same.	Dirt on the Printhead.	Run a cleaning cycle and make a test print. Repeat the operation several times. Does the problem still appear?	Clean the Printhead surface with a cotton swab.
	The absorber of the Cap Unit contacts with the Printhead surface during printing.	Is the absorber of the Cap Unit deformed or damaged?	Replace the Ink System.
	Head FFC failure	Is the Head FFC damaged or broken?	Replace the Head FFC.
	A malfunction of the Printhead	Run a cleaning cycle and print a nozzle check pattern. Repeat the operation several times. Does the problem still appear?	Replace the Printhead.
Missing dots appear sometimes.	Dirt on the Printhead.	Run a cleaning cycle and print a nozzle check pattern. Repeat the operation several times. Does the problem still appear?	Clean the Printhead surface with a cotton swab.
	Ink cartridge failure	Replace the ink cartridge with a new one, and print a nozzle check pattern. The printed pattern has no missing dots?	The cartridge is defective. Use the new cartridge.
	Poor connection of the Head FFC	Check the FFC with a tester. Does the result show poor connection of the FFC?	Replace the Head FFC.
	A malfunction of the Printhead	Run a cleaning cycle and print a nozzle check pattern. Repeat the operation several times. Does the problem still appear?	Replace the Printhead.
White streak / abnormal discharge	Poor connection of the Head FFC	Is the Head FFC not securely connected to the CR Unit and boards?	Connect the FFC correctly.
	A malfunction of the Printhead	Is the Head FFC not securely connected to the Printhead?	Connect the FFC correctly. If there is no problem with the connection status, replace the Printhead.
Vertical lines are misaligned.	Improper Bi-D adjustment	Using the Adjustment Program, check the Bi-D setting. Is the setting made properly?	Carry out the Bi-D adjustment properly.

Table 3-16. Troubleshooting Print Quality Problems

Symptom	Possible Cause	Check Point	Remedy
Printed image has white banding.	Dirt on the CR shaft	Is there any dirt on the CR shaft?	Clean off any dirt on the CR shaft surface with a dry soft cloth.
	PF Roller failure	Is there any dirt on the PF Roller?	Clean the PF Roller surface with a soft brush carefully so as not scratch it.
		Is the PF Roller damaged?	Replace the PF Roller.
	Ink cartridge failure	Replace the ink cartridge with a new one, and print a nozzle check pattern. The printed pattern has no missing dots?	The cartridge is defective. Use the new cartridge.
	A malfunction of Carriage movements	Are the carriage shaft and the Main Frame properly lubricated?	Apply G-71 grease referring to “Lubrication of CR Unit”(p.116) .
	Improper platen gap	Is the platen gap (gap between the Printhead surface and the platen) not properly set?	Adjust the platen gap properly.
	Some gear(s) is (are) damaged.	Is (are) the gear(s) in the paper feed and ASF mechanisms damaged?	Replace the damaged gear(s).
	Dirt on the Printhead is preventing nozzles from firing ink straight toward the paper.	Run a cleaning cycle and make a test print. Repeat the operation several times. Does the problem still appear?	Clean the Printhead surface with a cotton swab.
		Is there any dust or foreign matter on the Cleaner Blade?	Remove any dust or foreign matter on the Cleaner Blade, or replace the blade.
	A malfunction of the Printhead	Run a cleaning cycle and make a test print. Repeat the operation several times. Does the problem still appear?	Replace the Printhead.
CR shaft failure	Is the CR shaft not properly installed?	Reinstall the CR shaft properly.	
	Is the CR shaft surface damaged?	Replace the CR shaft.	

3.4.2 Power Problems

The printer does not work at all after power-on. LEDs do not light up.

Table 3-17. Troubleshooting Power Problems

Possible Cause	Check Point	Remedy
Power code failure	Replace the power code with a new one. Does the printer work normally?	The power code is defective. Use the new one.
Improper power supply	Do the power supplied from the AC line match with the electrical requirements of the printer?	Use an AC line that matches the printer electrical requirements.
Poor connection of the PS Assy connector	Is the PS Assy connector not properly connected to the Main Board?	Connect the connector properly.
The fuse burned out	Is the fuse (F1) on the PS Board burned out?	Replace the PS Board.
Abnormal voltage output of the PS Board	Check the voltage output from the PS Board. Is it abnormal?	When the voltage is normal: Replace the Main Board. When the voltage is abnormal: Replace the PS Assy.

3.4.3 Ink-related Problems

- Printer stops halfway through its initialization process or printing operation.

Table 3-18. Troubleshooting Ink Supply Problems

Symptom	Possible Cause	Check Point	Remedy
An Ink Out error occurs.	The cartridge is empty.	Is the ink cartridge empty?	Replace the cartridge with a new one.
A No Cartridge error occurs.	The printer cannot detect the ink cartridge.	Are ink cartridges not installed in the IC Holder?	Install ink cartridges.
		Are the ink cartridges not properly installed?	Set the cartridges properly.
		Are the top and bottom tabs of the ink cartridge broken?	Replace the cartridge with a new one.
An ink cartridge error occurs.	Ink cartridge is damaged.	Is the CSIC Board not properly attached?	Replace the cartridge with a new one.
		Is there any chipped or broken elements on the CSIC Board?	Replace the cartridge with a new one.

- Printing cannot be made properly (printed image is faint, blurry, smeared, or etc.)

Table 3-19. Troubleshooting Printing Problems

Symptom	Possible Cause	Check Point	Remedy
The carriage moves normally, but the printed image is abnormal.	Ink cartridge failure	Replace the ink cartridge with a new one, and make a test print. The printed pattern has no missing dots?	The cartridge is defective. Use the new one.
	Poor connection of the Head FFC	Is the FFC not properly connected to the CSIC Board and the Main Board?	Connect the FFC correctly.
	Cleaner Blade failure	Is there any dust or foreign matter on the Cleaner Blade?	Remove the dust or foreign matter on the Cleaner Blade, or replace the blade.
	Poor connection of the Head FFC	Check the FFC using a tester. Is there any abnormality in the result?	Replace the Head FFC.
	A malfunction of the Printhead	Run a cleaning cycle and make a test print. Repeat the operation several times. Does the problem still appear?	Replace the Printhead.
	Ink leakage, clogging	Is there any ink leakage found in the Printhead?	Reinstall the ink cartridge correctly. If this does not solve the problem, replace the ink cartridge, or the Printhead.

- Waste ink is not properly drained out of the Printhead or the Cap Unit.

Table 3-20. Troubleshooting Waste Ink Problems

Symptom	Possible Cause	Check Point	Remedy
Waste ink is not properly drained out of the Printhead or the Cap Unit, and not properly transported to the Waste Ink Tube.	The pump tube failure	Is there any collapsed sections of the tube?	Replace the Ink System.
	Cap failure	Is there any foreign matter on the cap, or is the cap damaged?	Remove the foreign matter on the cap with a cotton swab. Replace the cap in case that the cap is damaged.
	Disconnection of the tube	Is the tube disconnected from the Cap Unit?	Connect the tube correctly.
	A malfunction of cap movement	Is the Compression Spring of the Cap Assy detached, broken, or missing?	Replace the Ink System.
	The tube between the Waste Ink Tray and the Ink System Assy is at fault.	Is the tube not properly inserted in the Waste Ink Tray Assy, or not properly routed under the tray?	Securely connect the tube to the Waste Ink Tray Assy routing the tube correctly.

3.4.4 Problems with Interfaces

This section provides how to troubleshoot problems on the USB interface and memory card slot.

- USB interface error

Table 3-21. Troubleshooting USB Connection Errors

Possible Cause	Check Point	Remedy
The printer driver has not been installed correctly.	On the Windows PC, go to My Computer, Properties, Hardware, Device Manager. Is the printer driver associated with Other Devices?	Uninstall the driver and reinstall it correctly following the instruction described in the User's Guide.
USB cable failure	Replace the USB cable with a new one. Does the USB communication between the printer and PC return to normal?	The USB cable is defective. Use the new one.
Poor connection of the USB terminals	Is there any foreign matter on the USB terminal?	Remove the foreign matter.
Main Board failure	Is the Main Board damaged or broken?	Replace the Main Board.

CHAPTER

4

DISASSEMBLY/ASSEMBLY

4.1 Overview

This chapter describes procedures for disassembling the main components of the Stylus Photo R280/R285/R290.

Unless otherwise specified, disassembled units or components can be reassembled by reversing the disassembly procedure.

Procedures which, if not strictly observed, could result in personal injury are described under the heading “WARNING”.

“CAUTION” signals a precaution which, if ignored, could result in damage to equipment.

Important tips for procedures are described under the heading “CHECK POINT”.

If the assembly procedure is different from the reversed disassembly procedure, the correct procedure is described under the heading “REASSEMBLY”.

Any adjustments required after reassembly of components or parts are described under the heading “ADJUSTMENT REQUIRED”.

When you have to remove any components or parts that are not described in this chapter, refer to the exploded diagrams in the appendix.

The precautions in the two lists below (WARNING and CAUTION), must always be followed during disassembly and assembly.

4.1.1 Precautions

See the precautions given under the heading “WARNING” and “CAUTION” in the following column when disassembling Stylus photo R280/R285/R290.



- Disconnect the power cable before disassembling or assembling the printer.
- If you need to work on the printer with power applied, strictly follow the instructions in this manual.
- Wear protective goggles to protect your eyes from ink. If ink gets in your eye, flush the eye with fresh water and see a doctor immediately.
- Always wear gloves for disassembly and reassembly to avoid injury from sharp metal edges.
- Use static discharge equipment such as anti-static wrist straps when accessing internal components to protect sensitive electronic components and circuitry.
- Never touch the ink or wasted ink with bare hands. If ink comes into contact with your skin, wash it off with soap and water immediately. If irritation occurs, contact a physician.
- Make sure the tip of the waste ink tube is located at correct position when reassembling the waste ink tube, or it will cause ink leakage.



- When transporting, do not remove the ink cartridges. Pack the printer with the cartridges installed.
- Use only recommended tools for disassembly, assembly or adjustment of the printer. (Refer to "Table 4-1. List of Tools" (p.52))
- Be sure to tighten the screws to the specified torque.
- Apply lubricants and adhesives as specified. (See Chapter 6 Specified Lubricant (p.114) for details.)
- Make the specified adjustments when you disassemble the printer. (Chapter 5 contains additional information on adjustments.)
- When using compressed air products, such as air duster, for cleaning during repair and maintenance, the use of such products containing flammable gas is prohibited.
- Be careful not to scratch or damage the coating on exterior surface of the product during disassembly and reassembly.

4.1.2 Tools

Use only specified tools to avoid damaging the printer.

Table 4-1. List of Tools

Tool	Part No.
Phillips Screwdriver (No.1)	1080530
Phillips Screwdriver (No.2)	-
Flathead Screwdriver	-
Precision Screwdriver #1 (flathead)	-
Tweezers	-
Long-nose pliers	-
Acetate tape	1003963
2 pins (thinner than Ø2mm)	-
Strong tape	-

Note : All of the tools listed above are commercially available. EPSON provides the tools listed with EPSON tool code.

4.1.3 Screws

The screws used in the printer are as shown in the table below. Make sure you always use the correct type and number of screws. The numbers shown in the “No.” column appear throughout this chapter to indicate the screw type more clearly.

Table 4-2. List of Screw Types



No.	Description	Image
1	C.B.S. 3x6	
2	C.B.S. 3x10	
3	C.B.P. 3x8	

Table 4-2. List of Screw Types







No.	Description	Image
4	C.B.P. 3x10	
5	C.B.P. 2.6x8	
6	C.P. 3x4	
7	C.P. 3x6	
8	C.B.S.(P4) 3x6	
9	C.B.P.(P2) 3x8	

Table 4-3. Screw Types

Abbreviation	Full Name
C.B.S	Phillips Bind S-Tite
C.B.P	Phillips Bind P-Tite
C.P.	Phillips Pan head
C.B.S.(P4)	Phillips Bind S-Tite Sems R2

4.1.4 Making a Special Tool for CSIC Board

The CSIC board (refer to p.73) can be easily removed by using a special tool. The method for making the tool is described below.

1. Prepare a handle part of a clip, or a similar metal wire piece.

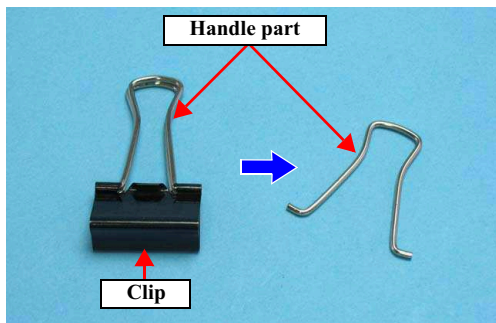

Figure 4-1. Making Special Tool for CSIC Board (1)

2. Bend the metal wire as shown below.

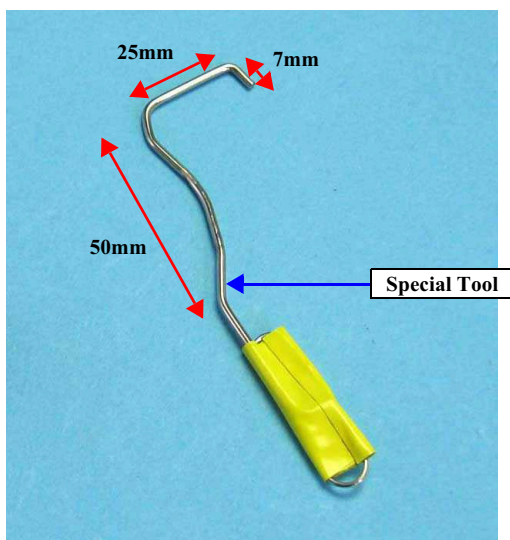

Figure 4-2. Making Special Tool for CSIC Board (2)

4.1.5 Work Completion Checklist

Whenever the printer is serviced, use the checklist shown below to confirm all work is completed properly and the printer is ready to be returned to the user.

Make sure to always check the maintenance counter before disassembling the printer. If the counter shows that some part or component has almost reached the end of its service life, replace the part after receiving prior approval from the user.

Table 4-4. Work Completion Checklist

Classification	Item	Check Point	Status
Printer Unit	Self-test	Is the operation normal?	<input type="checkbox"/> OK / <input type="checkbox"/> NG
	On-line Test	Is the printing attempt successful?	<input type="checkbox"/> OK / <input type="checkbox"/> NG
	Printhead (print a nozzle check pattern)	Is ink discharged normally from all the nozzles?	<input type="checkbox"/> OK / <input type="checkbox"/> NG
	Carriage Mechanism	Does the carriage move smoothly?	<input type="checkbox"/> OK / <input type="checkbox"/> NG
		Is there any abnormal noise during its operation?	<input type="checkbox"/> OK / <input type="checkbox"/> NG
	Paper Feeding Mechanism	Is paper advanced smoothly?	<input type="checkbox"/> OK / <input type="checkbox"/> NG
No paper jamming?		<input type="checkbox"/> OK / <input type="checkbox"/> NG	
No paper skew?		<input type="checkbox"/> OK / <input type="checkbox"/> NG	
No multiple-sheet feeding?		<input type="checkbox"/> OK / <input type="checkbox"/> NG	
No abnormal noise?		<input type="checkbox"/> OK / <input type="checkbox"/> NG	
Is the paper path free of obstructions?		<input type="checkbox"/> OK / <input type="checkbox"/> NG	
On-line Test	On-line Test	Is the operation normal?	<input type="checkbox"/> OK / <input type="checkbox"/> NG
Adjustment	Specified Adjustments	Are all the adjustments correctly completed?	<input type="checkbox"/> OK / <input type="checkbox"/> NG
Lubrication	Specified Lubrication	Has lubrication been applied at the specified points?	<input type="checkbox"/> OK / <input type="checkbox"/> NG
		Is the amount of lubrication correct?	<input type="checkbox"/> OK / <input type="checkbox"/> NG
Function	Firmware Version	Version:	<input type="checkbox"/> OK / <input type="checkbox"/> NG

Table 4-4. Work Completion Checklist

Classification	Item	Check Point	Status
Packing	Ink Cartridge	Are the ink cartridges installed correctly?	<input type="checkbox"/> OK / <input type="checkbox"/> NG
	Waste Ink Pads	Is the remaining capacity of the waste ink pads enough?	<input type="checkbox"/> OK / <input type="checkbox"/> NG
	Carriage position	Is the carriage located at the position where the Printhead is covered with the cap?	<input type="checkbox"/> OK / <input type="checkbox"/> NG
	Protection (strong tape, vinyl sheet)	Have the specified parts been secured with the strong tapes to prevent damage during transportation? See “Protection for transportation” (p.54)	<input type="checkbox"/> OK / <input type="checkbox"/> NG
Others	Attachments, Accessories	Have all the relevant items been included in/returned to the package?	<input type="checkbox"/> OK / <input type="checkbox"/> NG

PROTECTION FOR TRANSPORTATION

Before packing the printer to be returned to the user, attach several pieces of strong tape and vinyl sheet to the specified points to prevent damaging the printer during transportation.

- Securing the Carriage (tape: 180mm x 1 pc., fold one end by 5mm)
 1. Attach 40mm-length portion of the tape (not folded side) to the left side of the carriage aligning the tape’s corner with the carriage’s ribs as shown below.
 2. Attach the folded side of the tape to the housing with the carriage locked at its lock position. (First move the carriage to the lock position, then attach the tape to the housing.)

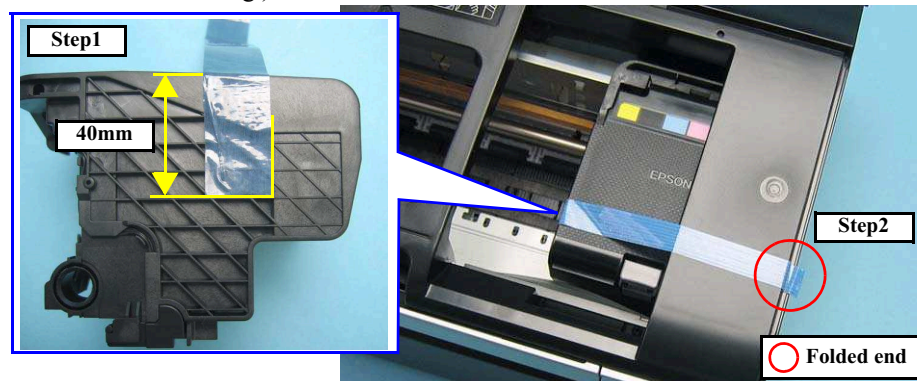

Figure 4-3. Securing the Carriage

DURAKLIN

- Securing the Paper Support Assy (tape: 80mm x 3 pcs., fold one end by 5mm)

Prepare a commercially available 280cm-width x 80cm-length vinyl sheet to avoid scratches on the exterior parts, and secure the sheet with strong tape.

Attach the strong tapes on both sides of the Paper Support Assy as shown in the figure below.

1. Fold the vinyl sheet in half and insert the folded sheet between the Paper Support Assy and the Printer Cover with the folded side facing the front side of the printer, and secure the sheet with the strong tape as shown below.
2. Attach the left and right tapes to the Paper Support Assy and the side of the housing.

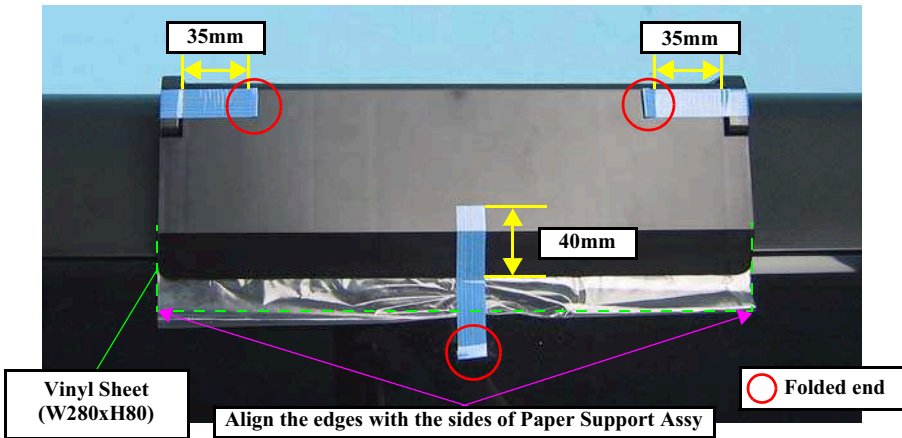

Figure 4-4. Securing the Paper Support Assy

- Securing the Stacker Assy (tape: 60mm x 1 pc., fold one end by 5mm)

Attach the strong tape to the center of the Stacker Assy as shown below.

The edge and backside of the Stacker have irregular steps. Make sure to attach the tape along the shape.

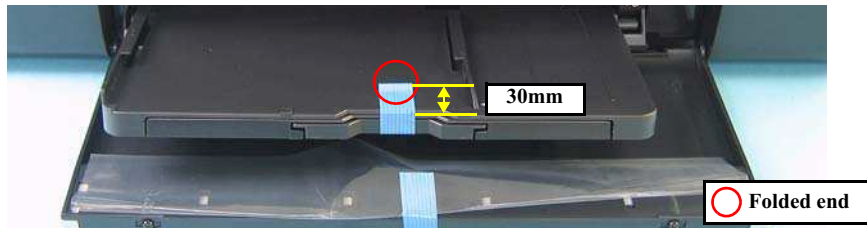

Figure 4-5. Securing the Stacker Assy

- Securing the Stacker Cover (tape: 60mm x 1 pc., fold one end by 5mm)

Have a commercially available 280mm-width x 80mm-length vinyl sheet to cover the exterior parts, and secure the sheet with strong tape.

- Fold the vinyl sheet in half, and insert the folded sheet between the Stacker Assy and the Stacker Cover with the fold facing front side of the printer. Align the left and right edges of the sheet with the edges of the Stacker Cover and secure the sheet with the strong tape as shown below.

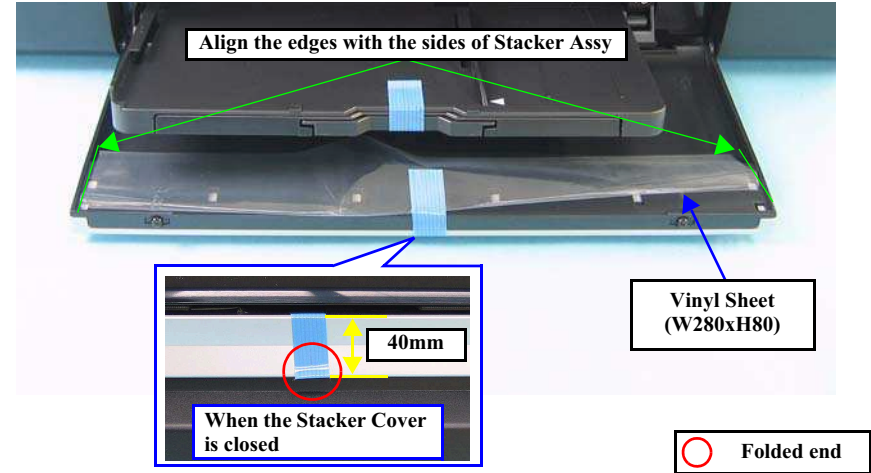

Figure 4-6. Securing the Stacker Cover

4.1.6 Required Preparation before Disassembly

Make sure to carry out the following operations before disassembling the printer.

- When the Main Board needs to be replaced, make a backup copy of EEPROM data.
- Unlock the carriage lock and move the CR Unit to other than its home position.
 - “4.1.8 How to Unlock the Carriage”

4.1.7 Orientation Definition

Orientation descriptions used in the disassembly/reassembly procedures are as follows.

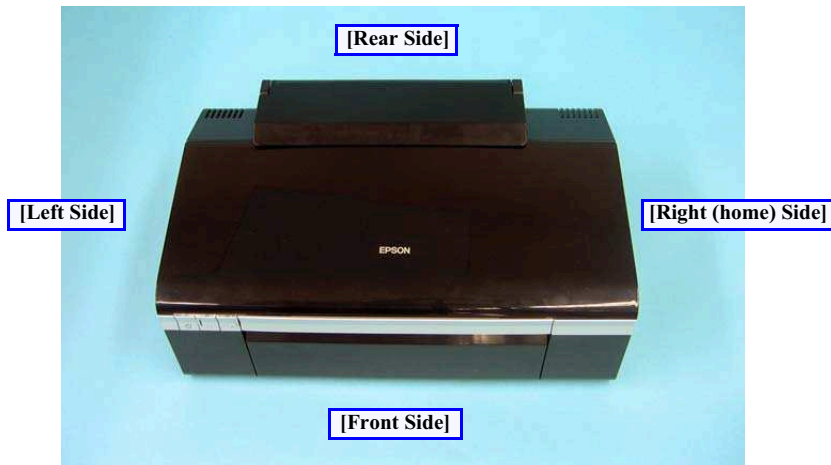

Figure 4-7. Orientation Definition

4.1.8 How to Unlock the Carriage

- Unlocking the carriage is required for disassembly of some parts or components. Carry out any of the following operations to unlock the carriage and move the carriage to other than its home position.



Be extremely careful not to damage the EJ Roller gear. Extra care must be taken to avoid injury from sharp metal edges.

- Power the printer and turn it off forcibly by disconnecting the power cable when the CR Unit is unlocked and moved away from the home position.
- Turn the EJ Roller gear on the left side of the printer in the direction of the arrow until the carriage is unlocked.

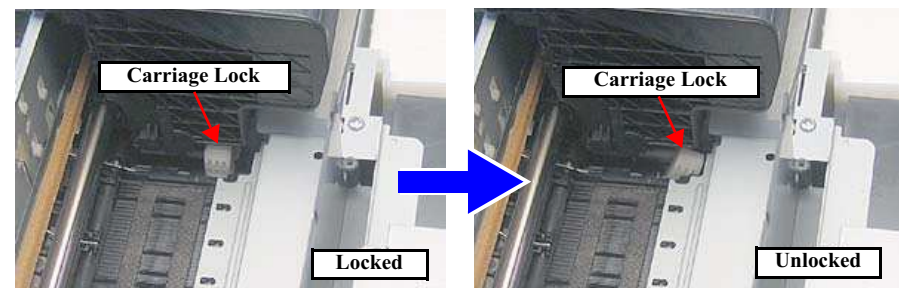
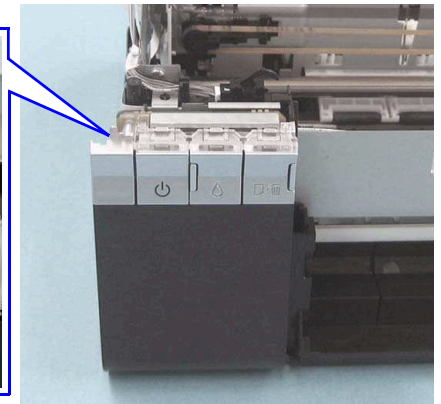
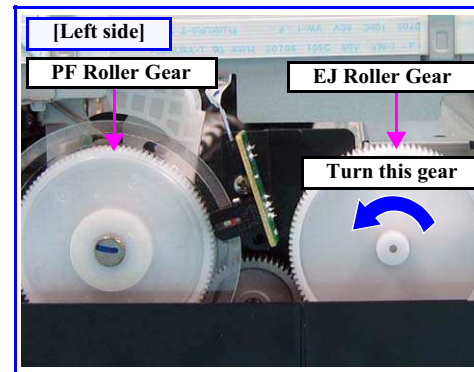
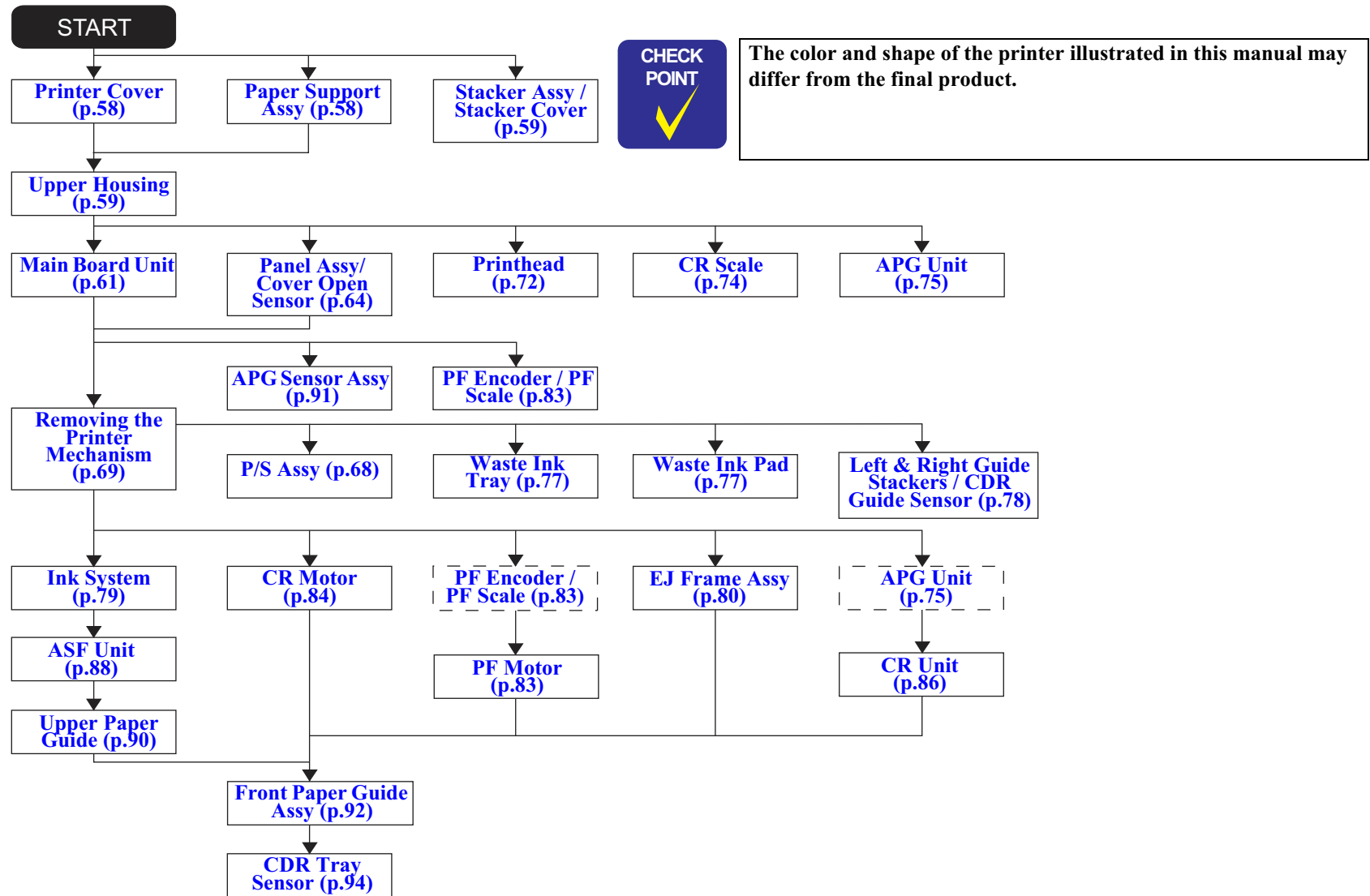

Figure 4-8. How to Unlock the Carriage

DURAKLIN

4.1.9 Disassembly Flowchart

The flowchart below shows step-by-step disassembly procedures. When disassembling each unit, refer to the page number shown in the figure.



Flowchart 4-1. R280/R285/R290 Disassembly Flowchart

4.2 Removing Exterior Parts/Components

4.2.1 Printer Cover

- Parts/Components need to be removed in advance: Nothing
- Removal procedure
 1. Pull out the left shaft and right shaft of the Printer Cover, and remove the Printer Cover.

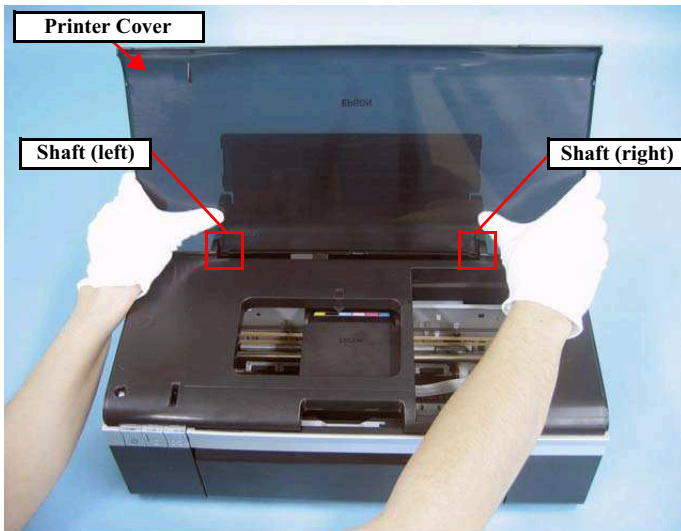

Figure 4-9. Removing the Printer Cover

4.2.2 Paper Support Assy

- Parts/Components need to be removed in advance: Nothing
- Removal procedure
 1. Open the Paper Support Assy.
 2. Disengage the right shaft of the Paper Support Assy from the bushing of the ASF Unit by pushing the bushing outward. Then remove the Paper Support Assy, disengaging the left shaft preventing the Edge Guide projection from hitting against the other parts.

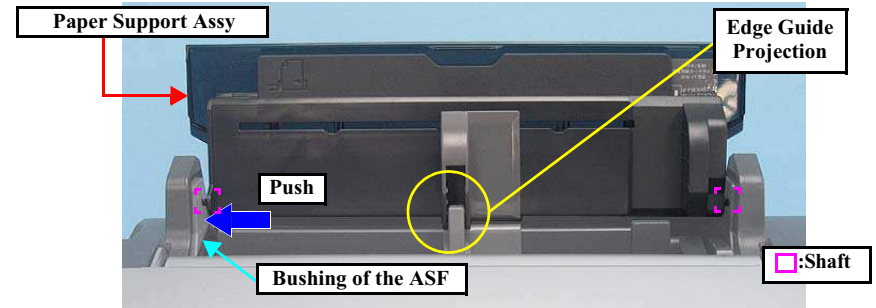

Figure 4-10. Removing the Paper Support Assy



When reinstalling the Paper Support Assy, match the projection and hole of the Edge Guide, then attach the right shaft and the left shaft in that order. (Put the shafts at the front side in the bushing and then push them rearward.) After reinstalling, check that the Paper Support Assy moves smoothly.

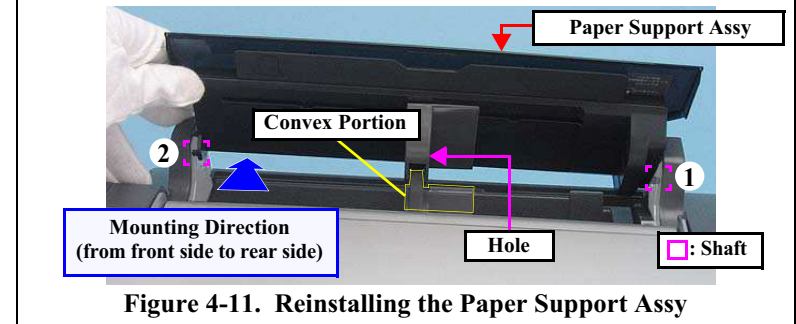

Figure 4-11. Reinstalling the Paper Support Assy

4.2.3 Stacker Assy / Stacker Cover

- Parts/Components need to be removed in advance: Nothing
- Removal procedure
 1. Open the Stacker Cover.
 2. Remove the Stacker Assy.
 3. Release the Stacker Cover from the two shafts and remove the Stacker Cover.

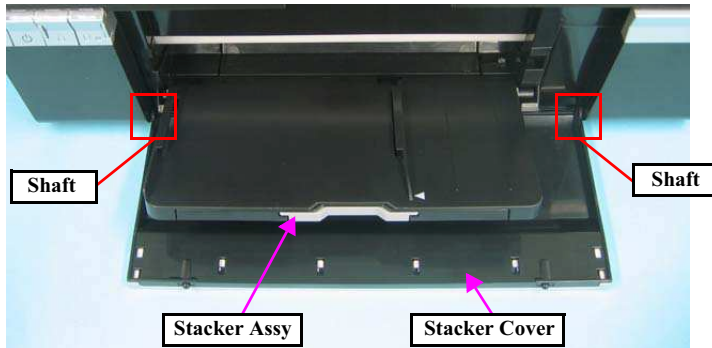

Figure 4-12. Removing the Stacker Assy / Stacker Cover



When installing the Stacker Assy, insert the guide pins of the Stacker Assy into the lower grooves of the Guide Stacker Assy. (The upper grooves are used when CDR is printed.)

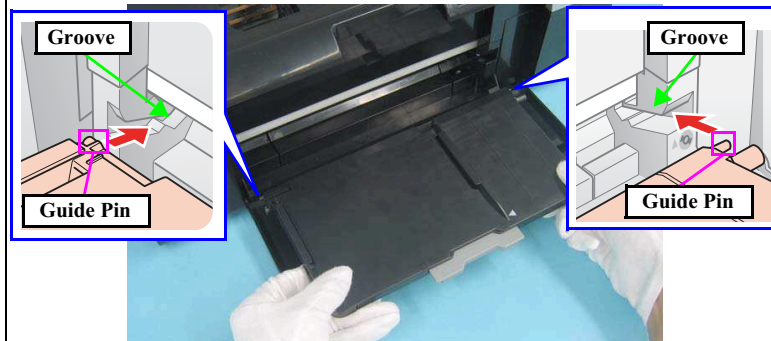

Figure 4-13. Installing the Stacker Assy

4.2.4 Upper Housing

- Parts/Components need to be removed in advance: Printer Cover / Paper Support Assy
- Removal procedure
 1. Remove the four screws and remove the Upper Housing upward.
 - Screw ○: C.B.P. M3x10 (tightening torque: 5-7 kgf.cm) (No.4)
 (The numbers shown in the figure indicate the order of tightening the screws.)

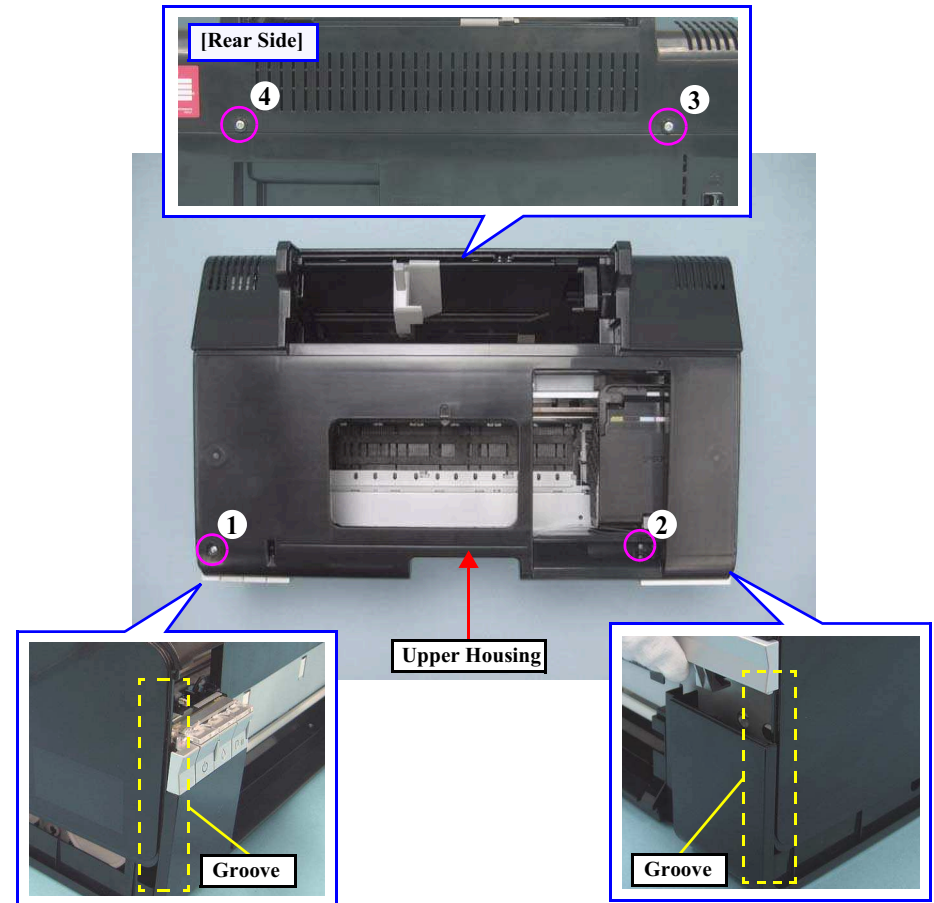

Figure 4-14. Removing the Upper Housing

2. Slide the Front Housing in the direction of the arrow and remove the Front Housing from the Upper Housing.

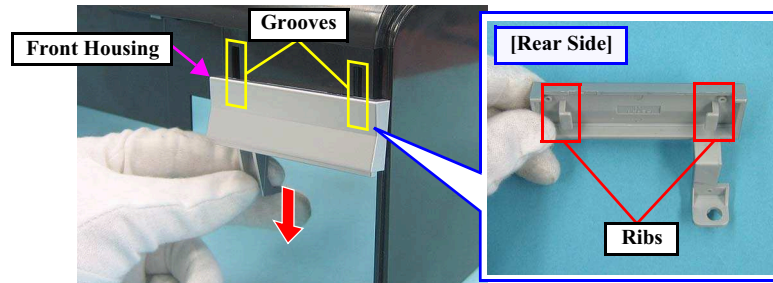

Figure 4-15. Removing the Front Housing

REASSEMBLY

When installing the Upper Housing, be careful of the following:

- Do not pinch the cables.
- Tighten the screws in the order given in Fig.4-14 (p.59).
- Match the ribs of the Upper Housing shown in Fig.4-14 (p.59) with the grooves of the Lower Housing.
- As shown in Fig.4-16, match the A part of the Front Housing with the screw box of the Lower Housing.

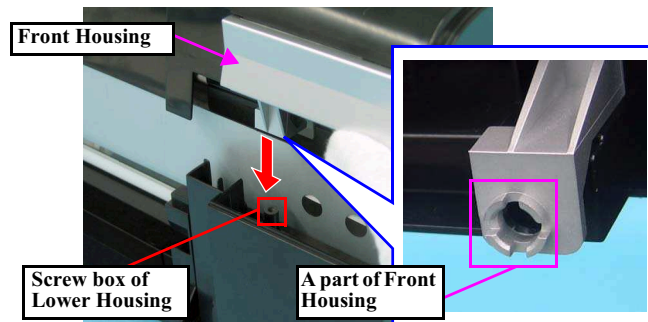

Figure 4-16. Installing Upper Housing

4.3 Removing Control Boards

4.3.1 Main Board Unit

- Parts/Components need to be removed in advance
Printer Cover / Paper Support Assy / Upper Housing
- Removal procedure
 - Main Board Unit removal
 1. Disconnect all connectors on the Main Board Unit.
 2. Peel off the double-sided tape that secures the Panel FFC to the Holder Frame and release the Panel FFC. (Fig.4-23 (p.64))

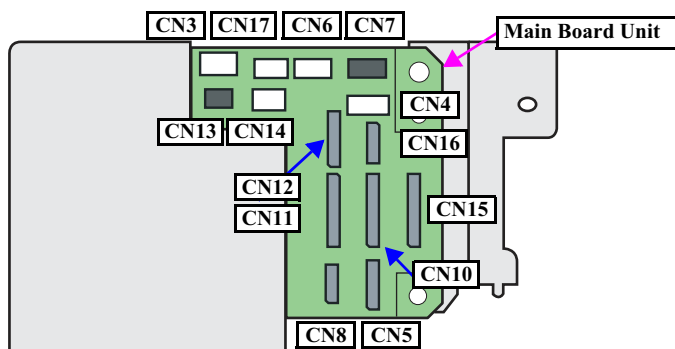

Figure 4-17. Connector layout of the Main Board

Table 4-5. List of Connectors and their Destinations

CN No.	Color	Destination	Number of pins
CN16	FFC	PW Sensor / CR Encoder Sensor	6pin
CN17	White	Cover Open Sensor	2pin

3. Peel off the four acetate tapes that secures the following cables on the back of the Main Board Unit.
 - Power Supply Cable
 - CR Motor Cable
 - PF Motor Cable
 - PE Motor Cable
 - APG Sensor Cable

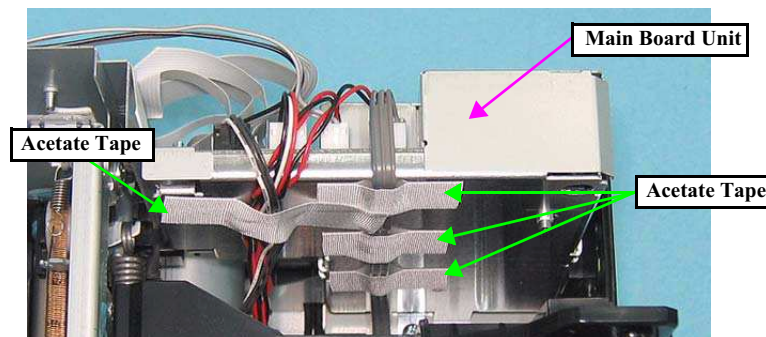



Figure 4-18. Removing the Main Board Unit (1)

Table 4-5. List of Connectors and their Destinations

CN No.	Color	Destination	Number of pins
CN3	White	P/S Assy	3pin
CN4	White	CDR Guide Sensor / CDR Tray Sensor	4pin
CN5	FFC	Panel Board	8pin
CN6	White	PE Sensor	3pin
CN7	Black	APG Sensor	3pin
CN8	FFC	PF Encoder	5pin
CN10	FFC	Head FFC	13pin
CN11	FFC		13pin
CN12	FFC		9pin
CN13	Black	PF Motor	2pin
CN14	White	CR Motor	2pin
CN15	FFC	CSIC Assy	13pin

4. Remove the three screws and remove the Main Board Unit.
- Screw  (2 pcs.): C.B.P.(P2) M3x8 (tightening torque: 5-7 kgf.cm) (No.9)
 - Screw  (1 pc.): C.B.S. M3x6 (tightening torque: 7-9 kgf.cm) (No.1)
- (The numbers shown in the figure indicate the order of tightening the screws.)

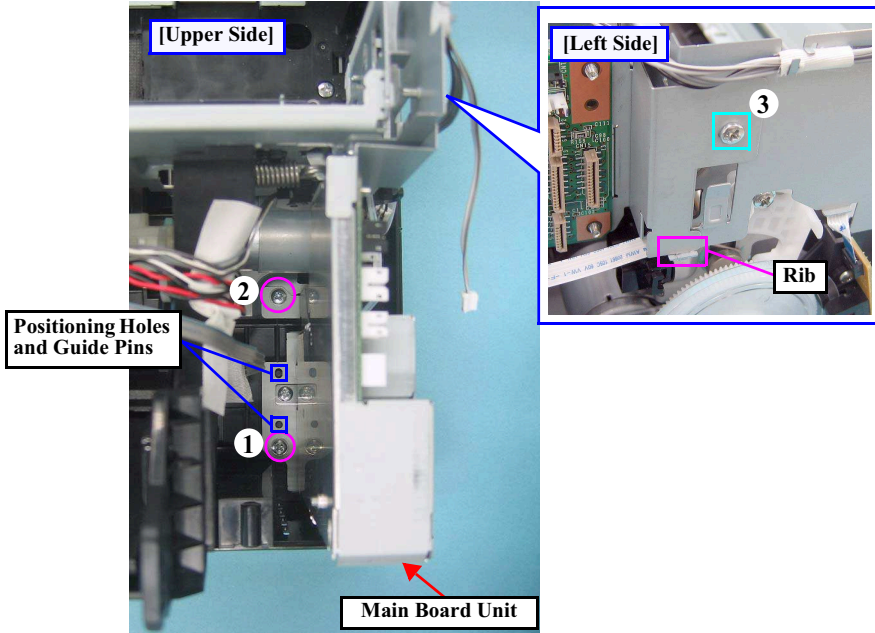

Figure 4-19. Removing the Main Board Unit (2)



Whenever the Main Board Unit is replaced, the required adjustment must be carried out.

- Refer to "5.1.2 Required Adjustments" (p.99)



When installing the Main Board Unit, be careful of the following:

- Match the positioning holes with guide pins shown in Fig.4-19.
- Insert the rib of the Main Board Unit into the positioning hole of the Cable Holder Frame as shown in Fig.4-19.
- Tighten the screws in the order given in Fig.4-19.

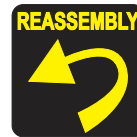

After connecting the cables, secure them with acetate tape following the procedures below.

1. Route the Power Supply Cable closely along the Lower Shield Plate M/B, and secure the cable with acetate tapes at the positions A, B, and C (30 mm each) as shown in Fig.4-20.
2. Avoiding the sharp edge shown in Fig.4-20, secure the following cables with the acetate tape D (50 mm).
 - Power Supply Cable
 - CR Motor Cable
 - PF Motor Cable
 - PE Motor Cable
 - APG Sensor Cable

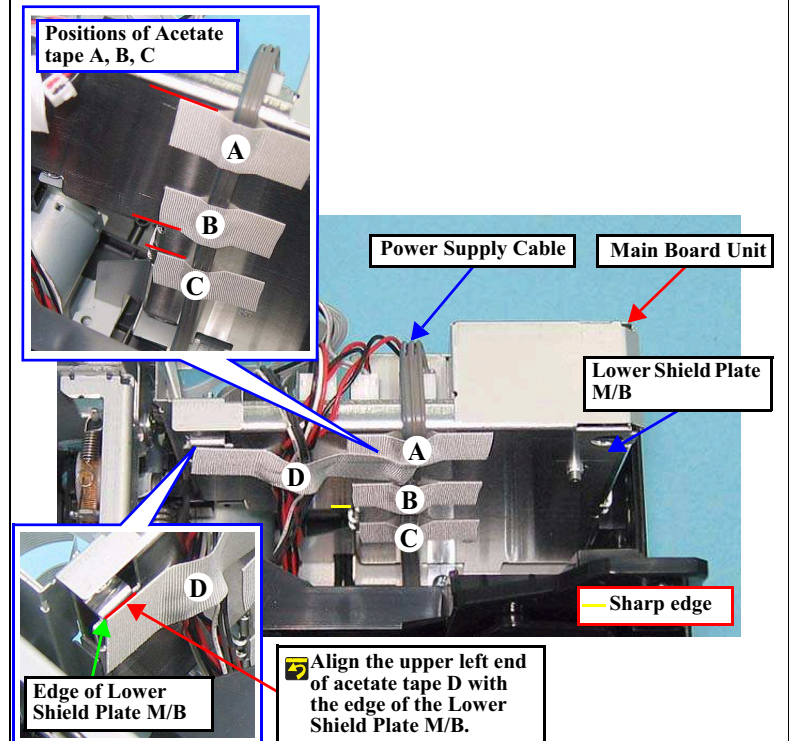



Figure 4-20. Routing the Cables

- Disassembling the Main Board Unit
- 1. Remove the Main Board Unit (p.61).



■ Do not apply unnecessary force on the screw receiving parts of the Lower Shield Plate M/B, as they are easy to deform.

■ When assembling or disassembling the Upper Shield Plate M/B, be careful of its sharp edges.

2. Remove the seven screws and remove the Upper Shield Plate M/B.
 - Screw  (6 pcs.): C.B.S. M3x6 (tightening torque: 5-7 kgf.cm) (No.1)
 - Screw  (1 pc.): C.P. M3x6 (tightening torque: 4-6 kgf.cm) (No.7)

(The numbers shown in the figure indicate the order of tightening the screws.)

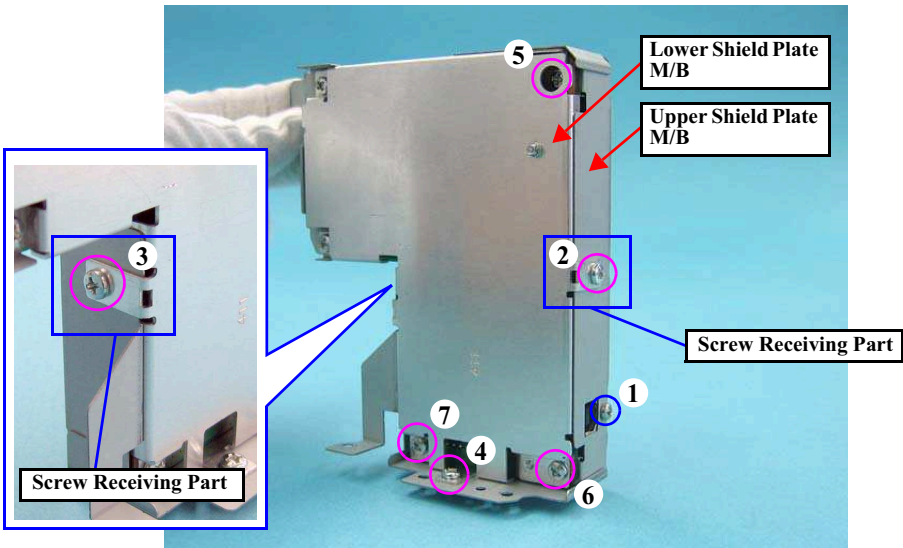



Figure 4-21. Removing the Upper Shield Plate M/B



Be careful of the sharp edges shown in the figure below when assembling or reassembling.

3. Remove the two screws and remove the Shield Plate M/B Sub.
 - Screw  (2 pcs.): C.B.S. M3x6 (tightening torque: 4-6 kgf.cm) (No.1)
(The numbers shown in the figure indicate the order of tightening the screws.)
4. Remove the screw and remove the Main Board Unit.
 - Screw  C.B.S. M3x10 (tightening torque: 4-6 kgf.cm) (No.2)

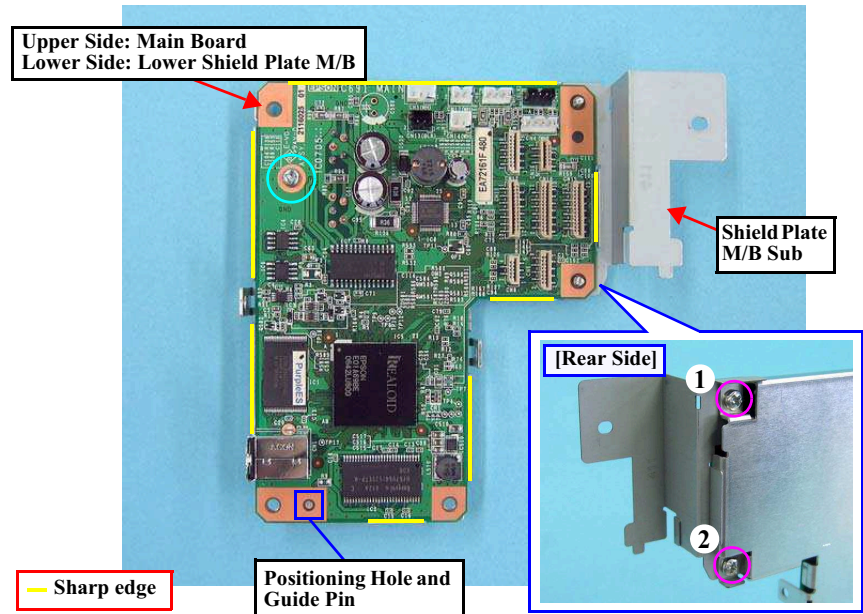

Figure 4-22. Removing the Main Board



■ When installing the Main Board, match the positioning hole with the guide pin shown in Fig.4-22.

■ Tighten the screws in the order given in Fig.4-21 (p.63), Fig.4-22.

4.3.2 Panel Assy/ Cover Open Sensor

- Parts/Components need to be removed in advance
Printer Cover / Paper Support Assy / Housing Upper
- Removal procedure

- Panel Assy removal

1. Peel off the acetate tape C.
2. Disconnect the Panel FFC from the connector (CN5) on the Main Board and peel the Panel FFC off the Cable Holder Frame.
3. Disconnect the CDR Sensor Cable and Cover Open Sensor Cable from the connectors (CN4, CN17) on the Main Board.
4. Release the CDR Sensor Cable and Cover Open Sensor Cable from the two hooks of the Cable Holder Frame.
5. Peel off the acetate tape A, B to separate the CDR Sensor Cable from the Cover Open Sensor Cable.

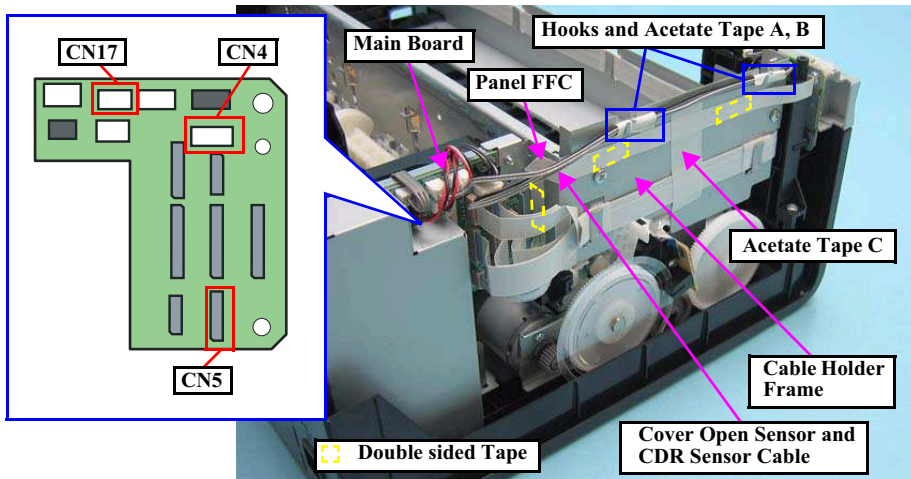

Figure 4-23. Removing the Panel Assy (1)



When removing the screw (2) shown in Fig.4-24, be careful not to damage the Cover Open Sensor Cable and CDR Sensor Cable.

6. Remove the two screws.
 - Screw (3 pcs.): C.B.P. M3x6 (tightening torque: 5-7 kgf.cm) (No.1)
 - Screw (3 pcs.): C.B.P. M3x10 (tightening torque: 5-7 kgf.cm) (No.4)
7. From the bottom of the Printer, insert a flathead screwdriver into the hole to disengage the tab, and remove the Panel Assy.

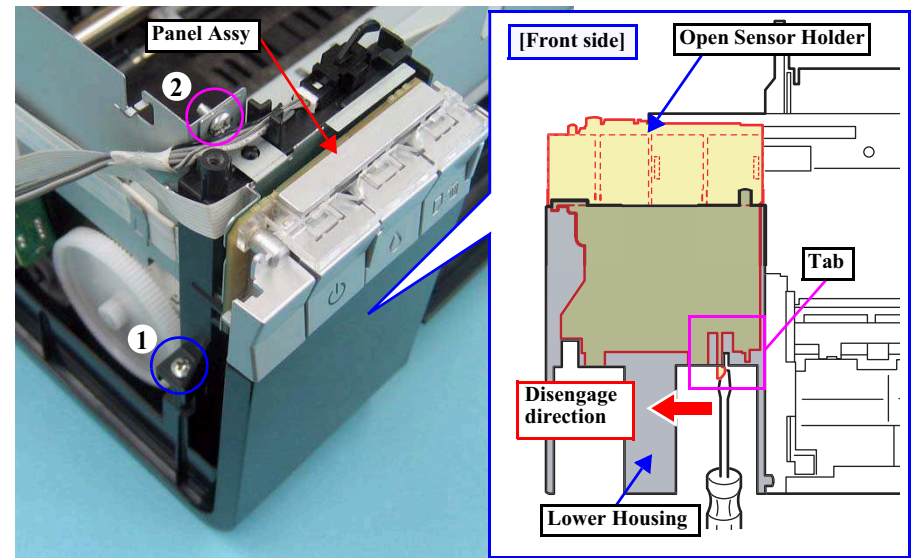

Figure 4-24. Removing the Panel Assy (2)



When Installing the Panel Assy, be careful of the following:

- Tighten the screws in the order given in Fig.4-24.
- When routing the FFCs and cables, follow the procedures below referring to Fig.4-25.
 1. Route the Panel FFC aligning its upper edge with the reference line marked on the Cable Holder Frame, and secure the FFC with double-sided tape.
 2. Attach the acetate tape C along with the edge of the Cable Holder Frame to secure the Panel FFC and Head FFC.
 3. Tie the two cables together using two pieces of acetate tape (20 mm each) so that the two tape positions come to the two hooks of the Cable Holder Frame respectively. The cables orientation must be as follows;
 - CDR cable: faces its black side upward
 - Cover Open Sensor cable: faces its gray side upward
 4. Route the cables through the two hooks of the Cable Holder Frame aligning the center of the tapes with the hooks.

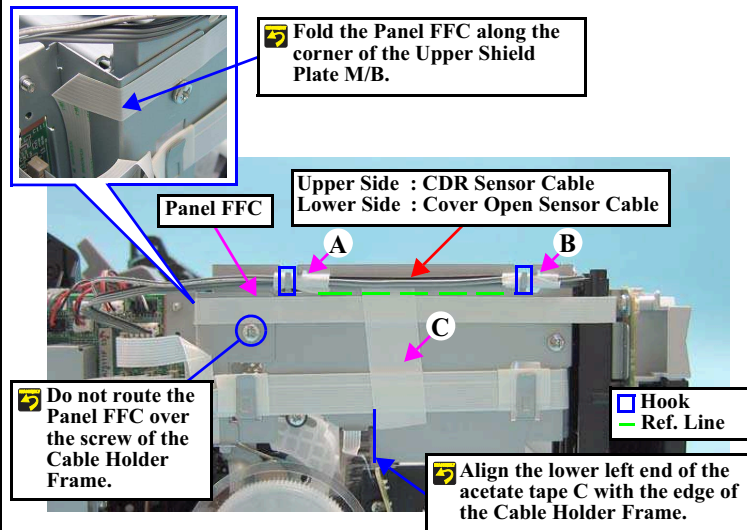

Figure 4-25. Routing the Cables



- As shown in Fig.4-26, route the CDR Sensor Cable and Cover Open Sensor Cable through the gap between the two ribs of the Open Sensor Holder.

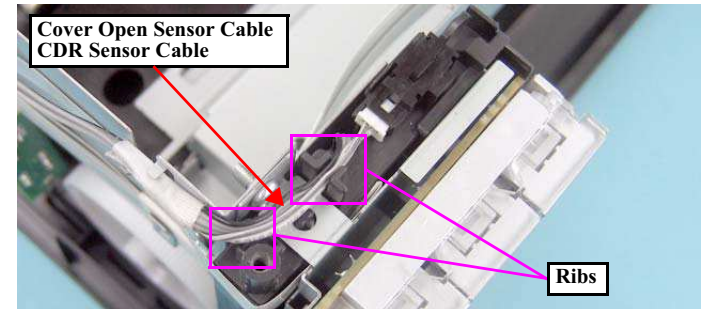

Figure 4-26. Installing the Panel Assy (1)

- As shown in Fig.4-24 (p.64) and Fig.4-27, match the positioning holes of the Open Sensor Holder with the guide pins of the Lower Housing, and secure the Open Sensor Holder with the tab.

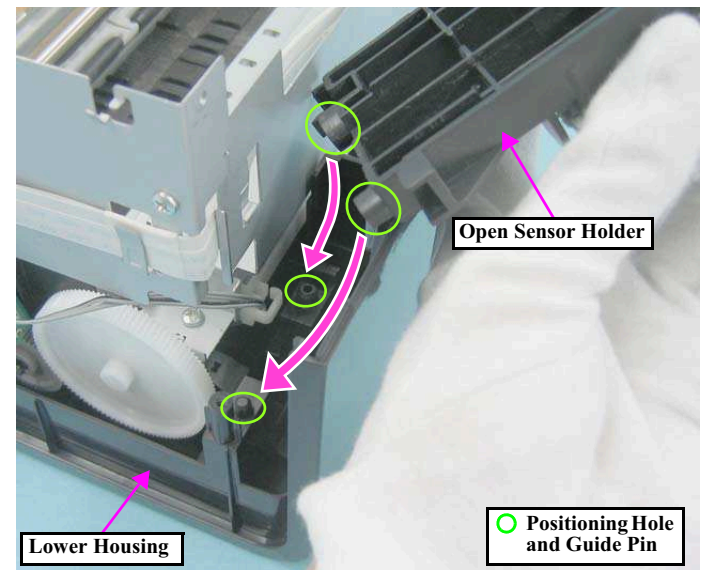



Figure 4-27. Installing the Panel Assy (2)

DURAKLIN

■ Panel Board / Buttons Removal

1. Remove the Panel Assy. (p.64)
2. Remove the screw of the Panel Unit.
 - Screw  : C.B.P. M3x10 (tightening torque: 3-5 kgf.cm) (No.4)
3. Slide the Panel Unit in the upper right direction and remove it.

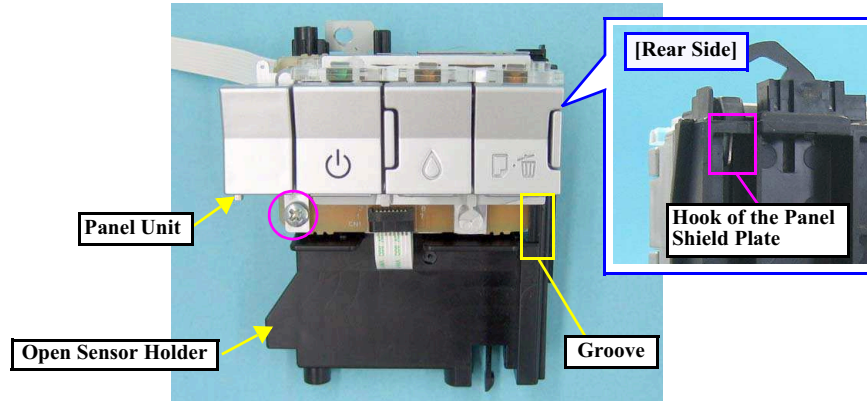



Figure 4-28. Removing the Panel Board / Buttons (1)

4. Disconnect the connector (CN1) on the Panel Board, peel the Panel FFC off the back of the Panel Shield Plate, and remove the Panel FFC.
5. Remove the two screws and remove the Panel Shield Plate from the Panel Unit.
 - Screw  : C.B.P. M3x10 (tightening torque: 3-5 kgf.cm) (No.4)

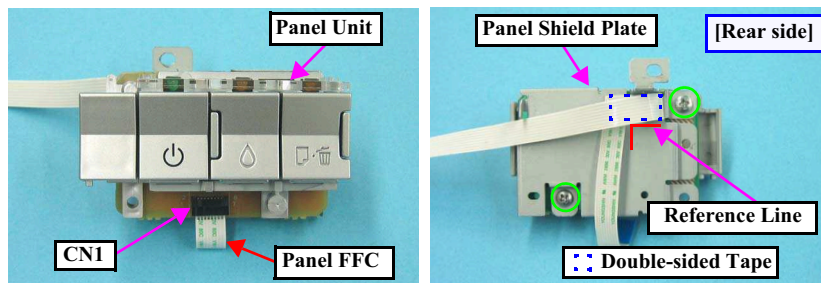

Figure 4-29. Removing the Panel Board / Buttons (2)

6. Disengage the hook on the back of the Panel Board and remove the Panel Board.

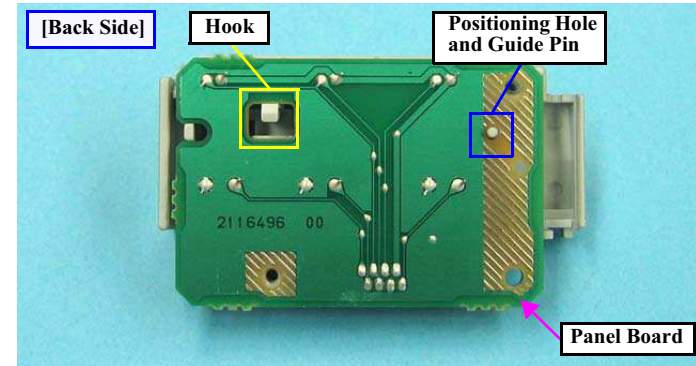

Figure 4-30. Removing the Panel Board / Buttons (3)

7. Release the liens from the guide pins of the Housing Panel B and remove the sense from the Housing Panel B.
8. Disengage the nine hooks and remove the PS button, Ink button, and Paper button.

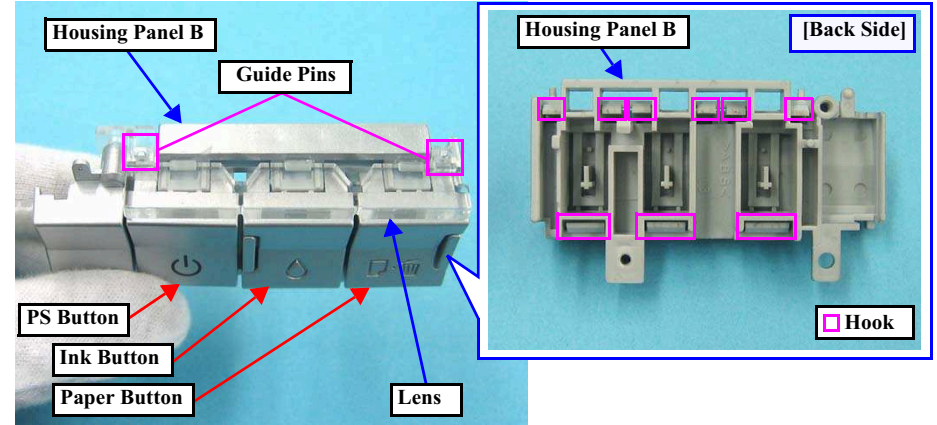

Figure 4-31. Removing the Panel Board / Buttons (4)



When installing the Panel Unit, be careful of the following:

- When installing the Panel Shield Plate to the Open Sensor Holder, match the hook and guide pins with the positioning holes shown in Fig.4-32 and insert the Panel Shield Plate into the groove of the Open Sensor Holder to secure the Panel Shield Plate.

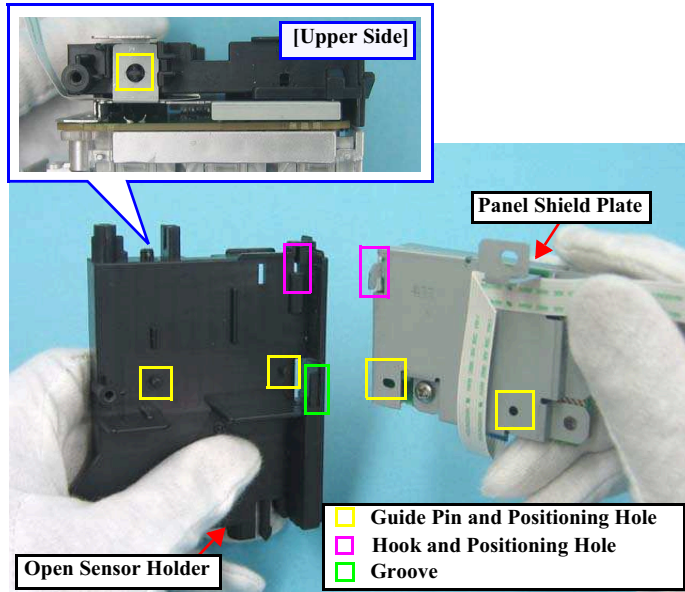

Figure 4-32. Installing the Panel Unit

- Attach the Panel FFC with double-sided tape along with the reference line shown in Fig.4-29 (p.66).
- When installing the Panel Board, match the guide pin with the positioning hole shown in Fig.4-30.
- Install the PS button, Ink button, and Paper button as shown in Fig.4-31.

■ Cover Open Sensor Removal

1. Remove the Panel Assy. (p.64)
2. From the back of the Open Sensor Holder, disengage the hook of the Cover Open Sensor, and remove the Cover Open Sensor pulling its rib out of the hole by rotating the sensor in the direction of the arrow.
3. Disconnect the connector from the Cover Open Sensor to remove the Cover Open Sensor.

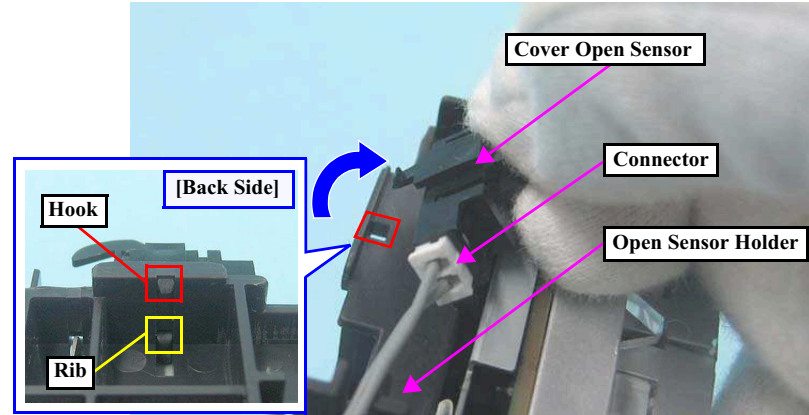



Figure 4-33. Removing the Cover Open Sensor



When installing the Cover Open Sensor, insert the rib shown in Fig.4-33 into the hole of the Open Sensor Holder, and secure the Cover Open Sensor with the hook.

4.3.3 P/S Assy

- Parts/Components need to be removed in advance
Printer Cover / Paper Support Assy / Upper Housing / Main Board Unit / Panel Assy / Cover Open Sensor / Printer Mechanism
- Removal procedure
 1. Peel off the acetate tape and remove the ferrite core from the groove of the Lower Housing.
 2. Remove the screw that secures the P/S Assy, and remove the P/S Assy from the Lower Housing.
 - Screw  : C.B.P M3x10 (tightening torque: 5-7 kgf.cm) (No.4)

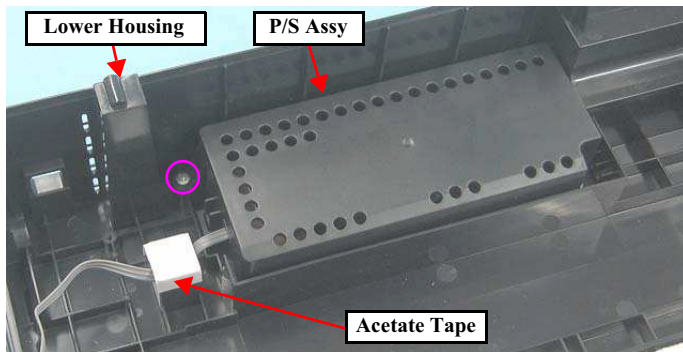

Figure 4-34. Removing the P/S Assy



When installing the P/S Assy, put the ferrite core into the groove of the Lower Housing and secure it with acetate tape as shown in [Fig.4-34](#).



Whenever the P/S Assy is replaced, the required adjustment must be carried out.

- [Refer to "5.1.2 Required Adjustments" \(p.99\)](#)

4.4 Disassembling the Printer Mechanism

4.4.1 Removing the Printer Mechanism

- Parts/Components need to be removed in advance
Printer Cover / Paper Support Assy / Upper Housing / Main Board Unit / Panel Assy / Cover Open Sensor
- Removal procedure



- Be careful of the four sharp edges shown in the figure below when assembling or reassembling.
- Printer Mechanism Handling Precaution
When lifting the printer, hold parts shown in the figure below to prevent the frame from deforming.

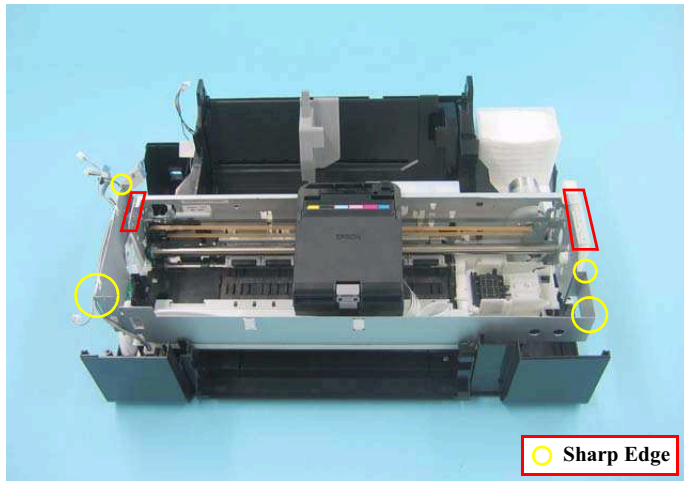

Figure 4-35. Printer Mechanism Handling Precaution (1)



- Do not touch the PF Scale with bare hands or damage it.
- If the Printer Mechanism is tilted leftward about 15°, the PF Scale hits against the desk surface and can break. After removing the Printer Mechanism, take extra care to protect the PF Scale.

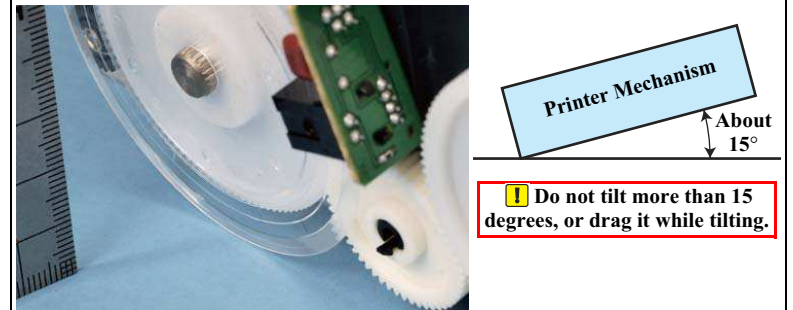

Figure 4-36. Printer Mechanism Handling Precaution (2)

1. Disengage the hook of the Ink Tube Cover using a flathead screwdriver and remove the Ink Tube Cover.

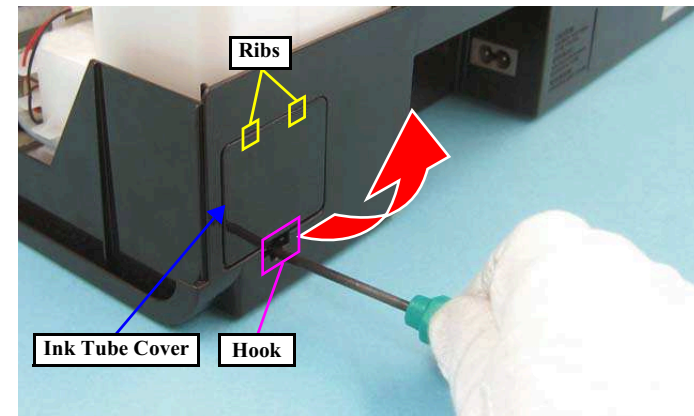

Figure 4-37. Removing the Ink Tube Cover



- When removing the Waste Ink Tube, take care not to contaminate the printer and surroundings with ink.
- Extra care must be exercised not to scratch or damage the Waste Ink Tube.

2. Pull out the Waste Ink Tube by hand.

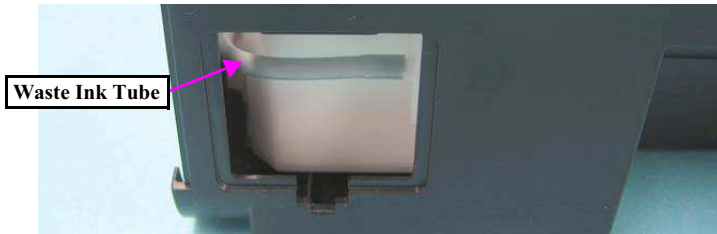

Figure 4-38. Removing the Waste Ink Tube

3. Release the Waste Ink Tube from the groove of the Waste Ink Tray.
4. Release the CR Motor Cable from the two ribs of the Waste Ink Tray.

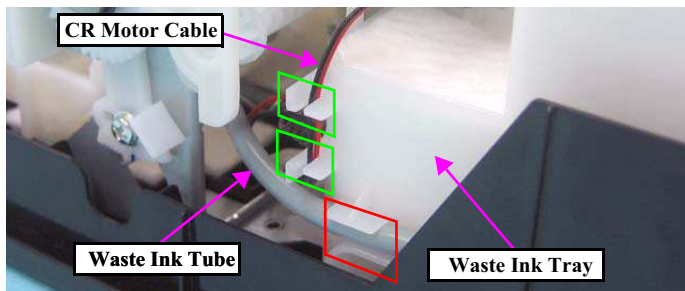

Figure 4-39. Removing the Printer Mechanism (1)

5. Remove the screw and remove the Cover Case.
Screw : C.B.P. M3x8 (tightening torque:5-7 kgf.cm) (No.3)

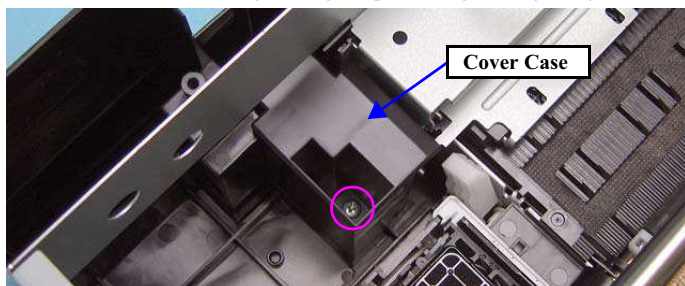

Figure 4-40. Removing the Cover Case

6. Disconnect the connector of the CDR Guide Sensor.

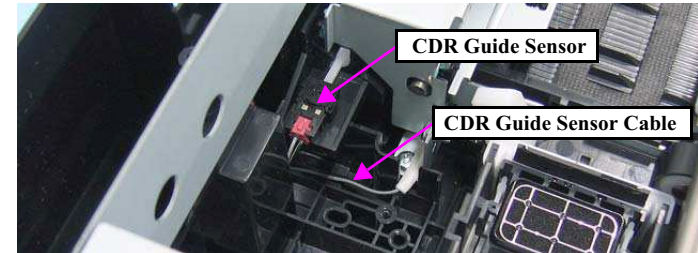

Figure 4-41. Removing the Printer Mechanism (2)

7. Remove the five screws and remove the Printer Mechanism.
Screw : C.B.P.(P2) M3x8 (tightening torque:5-7 kgf.cm) (No.9)
(The numbers shown in the figure indicate the order of tightening the screws.)

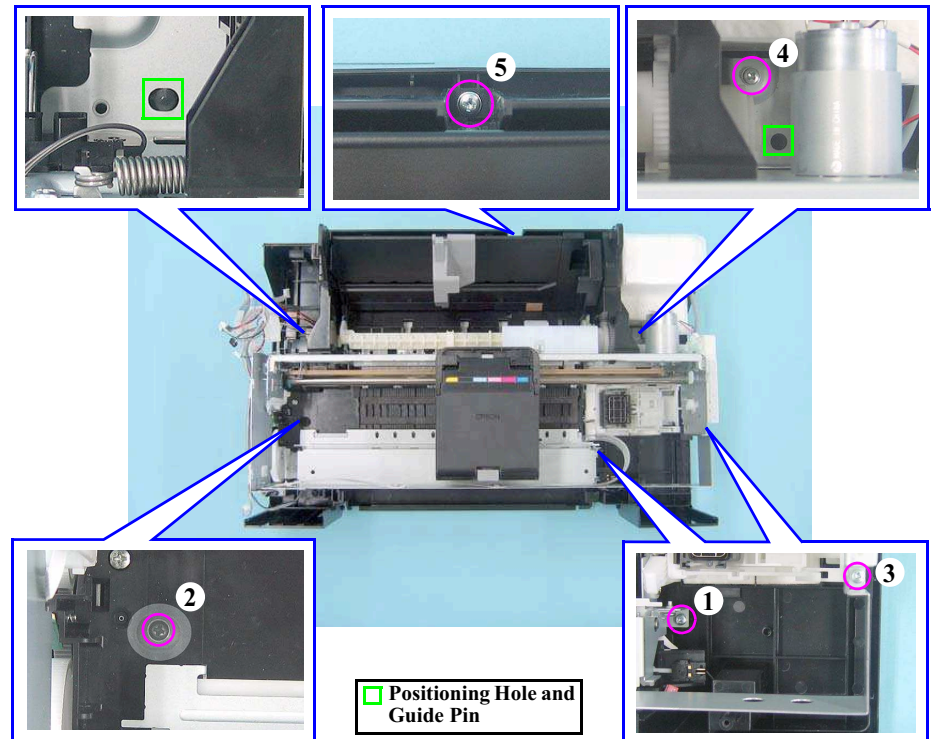

Figure 4-42. Removing the Printer Mechanism (3)

REASSEMBLY



When installing the Printer Mechanism, be careful of the following:

- Secure the Ink Tube Cover with the hook after inserting the two ribs shown in Fig.4-37 (p.69).
- Wipe off any ink on the joint portion of the Waste Ink Tube before reconnecting the tube. Ink on the joint portion makes the tube likely to get disconnected.
- As shown in Fig.4-43, insert the Waste Ink Tube over the tube of the Waste Ink Tray until the top end of the Waste Ink Tube contacts with the rib.

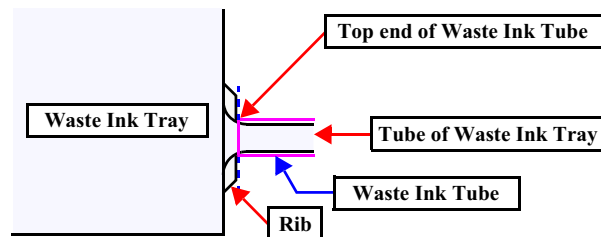

Figure 4-43. Cautions of inserting the Waste Ink Tube

- Match the positioning holes with guide pins (two pairs) shown in Fig.4-42 (p.70).
- Tighten the screws in the order given in Fig.4-42 (p.70).
- Make sure the Waste Ink Tube or cables are not pinched between the Printer Mechanism and the Lower Housing.

REASSEMBLY



- When installing the Cover Case, match the two guide pins and their two positioning holes ○ as shown in Fig.4-44.
- Route the CDR Guide Sensor Cable through the opening as shown in Fig.4-44.

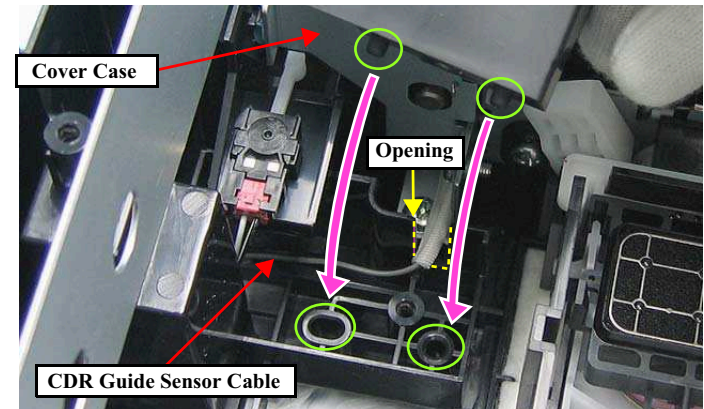

Figure 4-44. Installing the Cover Case

ADJUSTMENT
REQUIRED

Whenever the Printer Mechanism is replaced, the required adjustments must be carried out.

- Refer to "5.1.2 Required Adjustments" (p.99)

4.4.2 Printhead



- When removing the Head FFC Cover and the Head FFC Cover Inner, do not use tools with sharp ends as the FFC may get damaged.
- Be careful not to damage the FFC and cables when disengaging the hook of the CSIC Assy.

- Parts/Components need to be removed in advance
Printer Cover / Paper Support Assy / Upper Housing
- Removal procedure



See the section given below on how to unlock the carriage.

- “4.1.8 How to Unlock the Carriage”

1. Move the CR Unit to the center, open the Cartridge Cover and remove all Ink Cartridges.
2. While disengaging the hook of the Head FFC Cover with a flathead screwdriver, slide the Head FFC Cover downward and remove it.

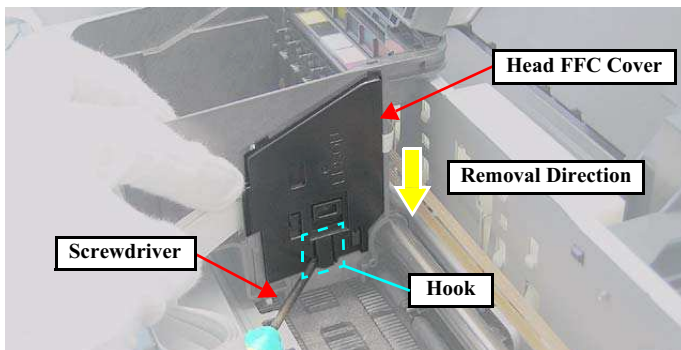

Figure 4-45. Removing the Head FFC Cover

3. Disconnect the CSIC FFC from the connector () on the CSIC Board.

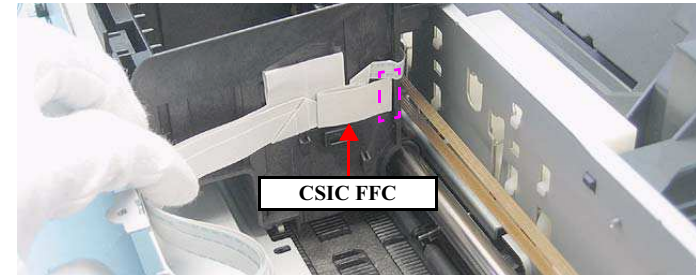

Figure 4-46. Removing the CSIC FFC

4. While disengaging the hook of the Head FFC Cover Inner with a flathead screwdriver, slide the Head FFC Cover Inner upward and remove it.

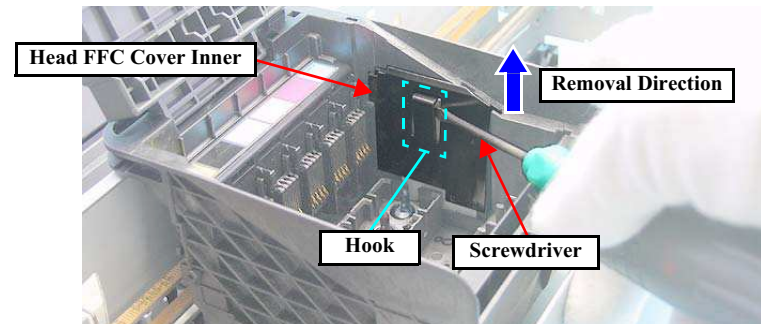

Figure 4-47. Removing the Head FFC Cover Inner

- Using the special tool (see p.53) disengage the hook A of the CSIC Assy on the left back of the Carriage Unit.

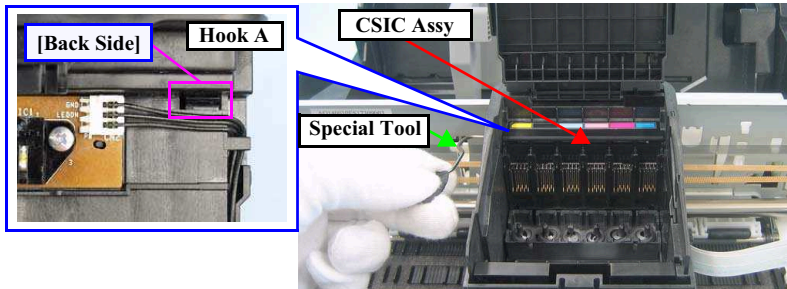

Figure 4-48. Removing the CSIC Assy (1)

- Using the special tool (see p.53) disengage the hook B of the CSIC Assy on the right back of the Carriage Unit.
- Slide the CSIC Assy upward and remove the CSIC Board.

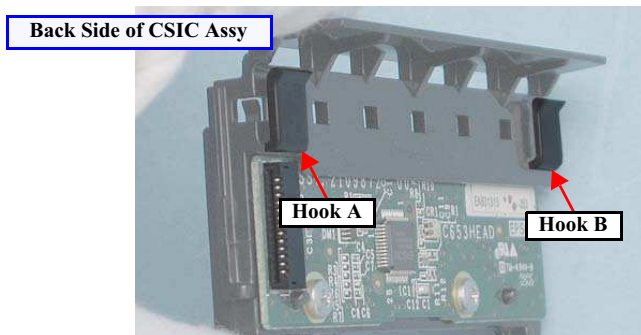
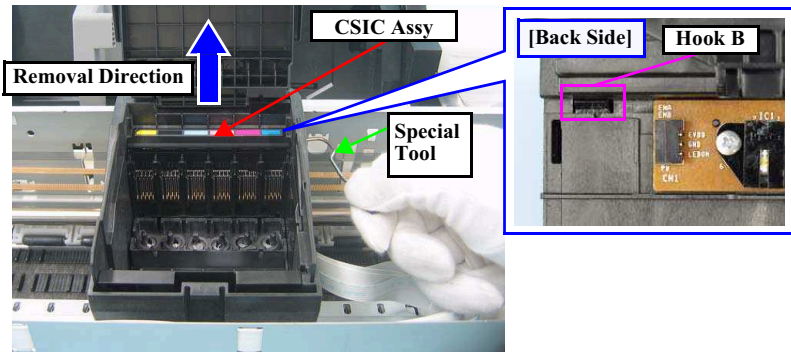

Figure 4-49. Removing the CSIC Assy (2)



Take extra care not to spill ink and contaminate the surroundings. Be extremely careful not to touch the nozzle surface, the ink supply needles and the Head Cover, otherwise the nozzles may get clogged.

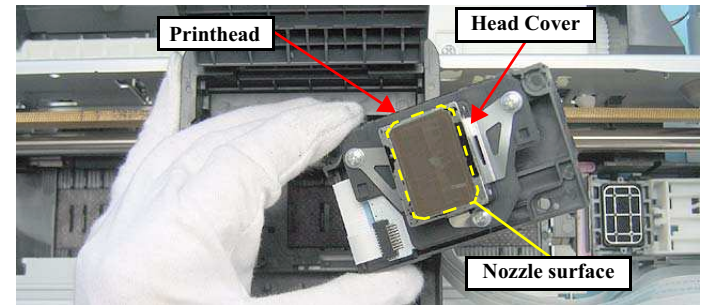



Figure 4-50. Handling of the Printhead

- Remove the three screws and remove the Printhead.
 - Screw  : C.B.P. M2.6x8 (tightening torque: 3-5 kgf.cm) (No.5)
(The numbers shown in the figure indicate the order of tightening the screws.)

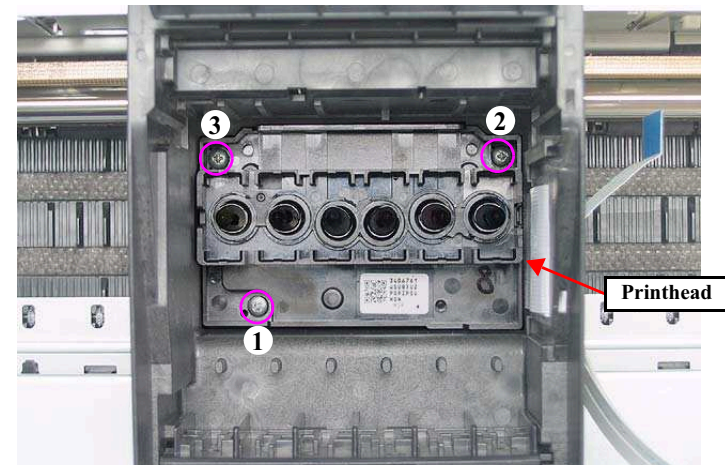

Figure 4-51. Removing the Printhead (1)

- Remove the two Head FFCs from the connectors on the back, and remove the Printhead.

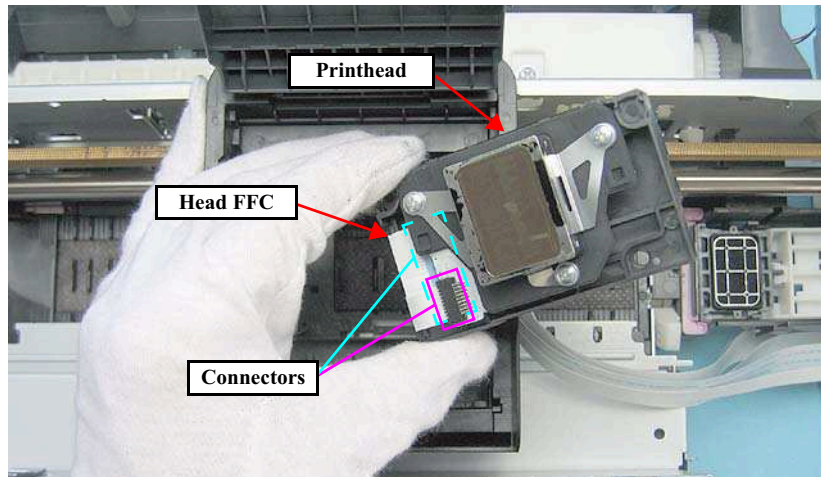

Figure 4-52. Removing the Printhead (2)



Tighten the screws in the order given in Fig.4-51.



Whenever the Printhead is removed/replaced, the required adjustments must be carried out.
 • Refer to "5.1.2 Required Adjustments" (p.99)

4.4.3 CR Scale



During the disassembly/reassembly of the Printer Mechanism, take extra care not to touch the CR Scale with bare hands, and not to contaminate or scratch it.

- Parts/Components need to be removed in advance
Printer Cover / Paper Support Assy / Upper Housing
- Removal procedure



See the section given below on how to unlock the carriage.
 • "4.1.8 How to Unlock the Carriage"

- Unlock the carriage and move the CR Unit to the center.
- Remove the Torsion Spring from the hook (○) on the left side of the Main Frame.
- Remove the CR Scale from the hook (□) on the right side of the Main Frame.
- Pull out the CR Scale from the slit of the CR Unit.
- Turn the CR Scale 90 degrees in the direction of the arrow, and remove the CR Scale from the hook.

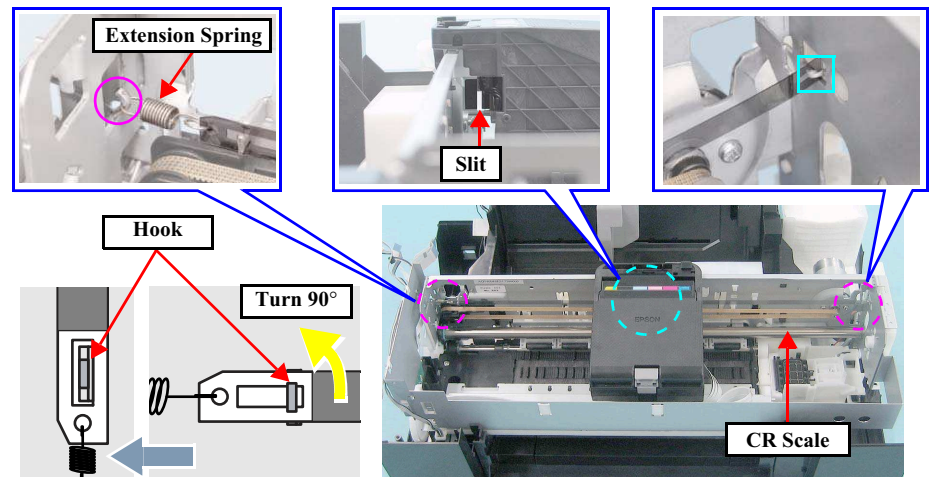

Figure 4-53. Removing the CR Scale

REASSEMBLY



Install the CR Scale with its cut-corner facing upward. Hitch one end of the Torsion Spring to the hole of the CR Scale from the back side of the CR Scale.

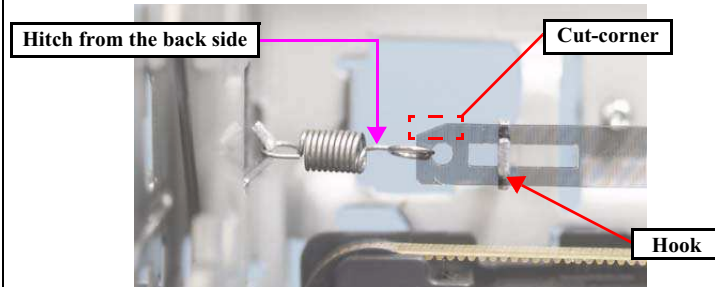



Figure 4-54. Reinstalling the CR Scale

4.4.4 APG Unit

- Parts/Components need to be removed in advance
Printer Cover / Paper Support Assy / Upper Housing
- Removal procedure
 1. Remove the two screws taking care not to lose the gears, and remove the APG Unit.
 - Screw : C.B.S. M3x6 (tightening torque: 7-9 kgf.cm) (No.1)
(The numbers shown in the figure indicate the order of tightening the screws.)

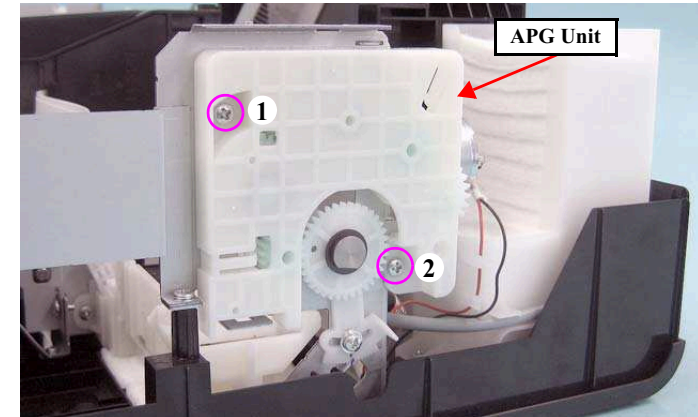

Figure 4-55. Removing the APG Unit

2. Remove the Combination Gear (10, 15.2).

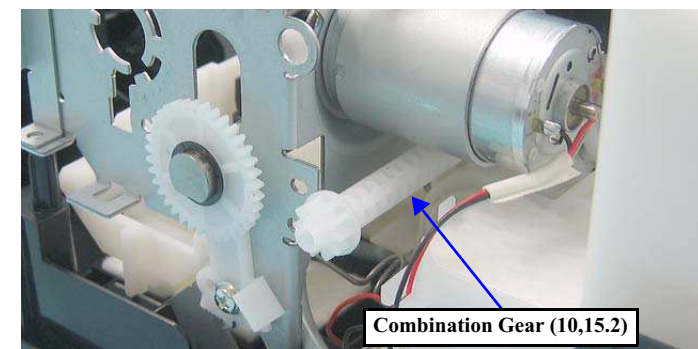

Figure 4-56. Removing the Combination Gear (10, 15.2)

REASSEMBLY



- Lubrication is required. See the page given below for the lubrication information.
[Lubrication of APG Unit \(p.117\)](#)
- Install the APG Unit following the procedure below.
 1. Put a pin (thinner than Ø2mm) through the positioning holes of the Main Frame and the right PG Cam on the CR Shaft.

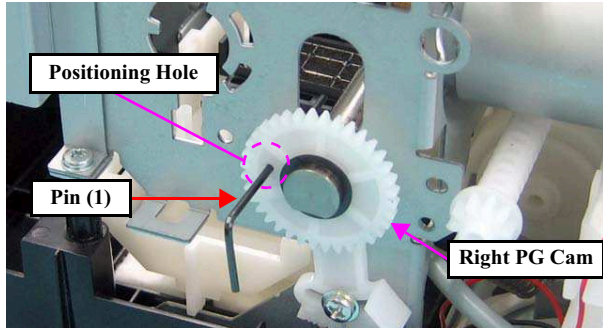

Figure 4-57. Reinstalling the APG Unit (1)

2. Put the pin through the positioning holes of the Spur gear 28.8 and the APG Unit.

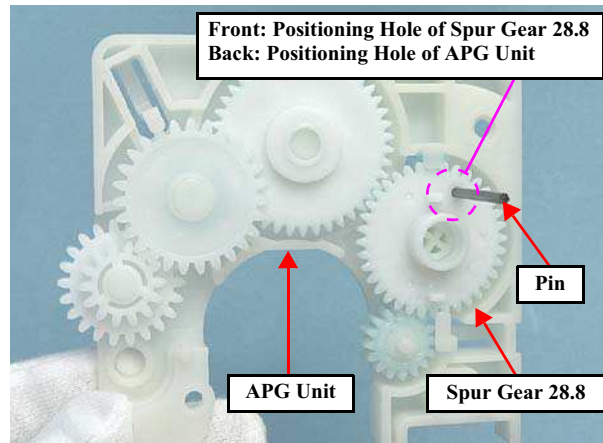

Figure 4-58. Reinstalling the APG Unit (2)

REASSEMBLY



3. Install the APG Unit to the Main Frame.

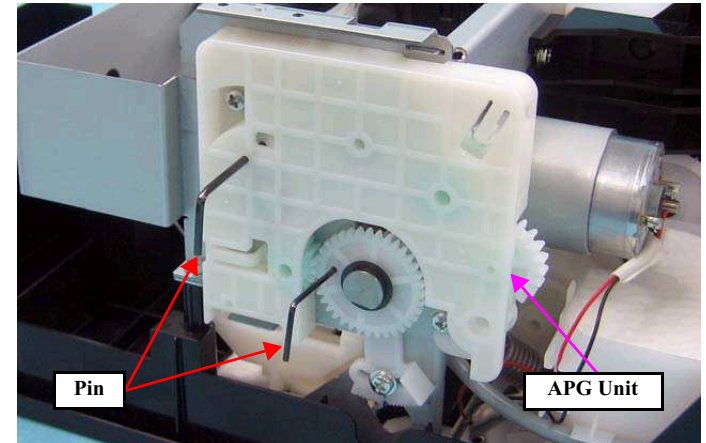

Figure 4-59. Reinstalling the APG Unit (3)

4. Check that the hooks (□) are attached to the positioning holes of the Main Frame, then screw the APG Unit.

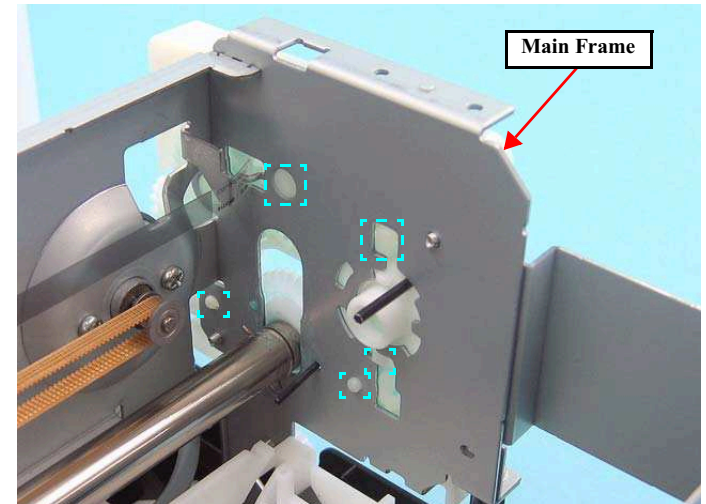

Figure 4-60. Reinstalling the APG Unit (4)

- Tighten the screws in the order given in [Fig.4-55 \(p.75\)](#).

DURAKLIN

4.4.5 Waste Ink Tray

- ❑ Parts/Components need to be removed in advance
Printer Cover / Paper Support Assy / Upper Housing / Main Board Unit / Panel Assy / Cover Open Sensor / Printer Mechanism
- ❑ Removal procedure



When removing the Waste Ink Tray, take extra care not to spill ink and contaminate the printer and surroundings.

1. Remove the two screws, disengage the hook, and remove the Waste Ink Tray.
 - Screw : C.B.P. M3x10 (tightening torque: 5-7 kgf.cm) (No.4)

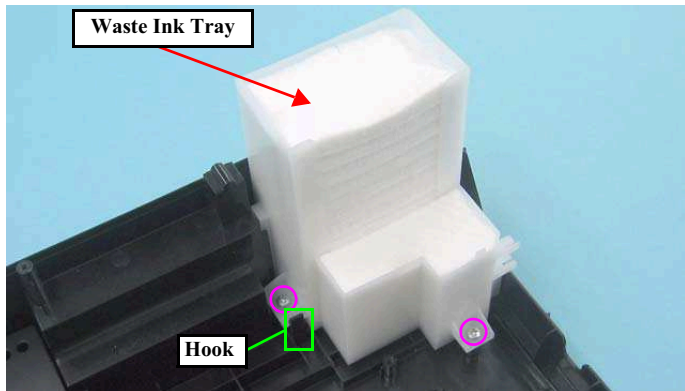

Figure 4-61. Removing the Waste Ink Tray



Whenever the Waste Ink Tray is replaced, the required adjustments must be carried out.

- Refer to "5.1.2 Required Adjustments" (p.99)

4.4.6 Waste Ink Pad

- ❑ Parts/Components need to be removed in advance
Printer Cover / Paper Support Assy / Upper Housing / Main Board Unit / Panel Assy / Cover Open Sensor / Printer Mechanism
- ❑ Removal procedure



When removing the Waste Ink Pad, take extra care not to contaminate the printer and surroundings with ink.

Be careful of the seven sharp edges shown in Fig.4-62 when disassembling or reassembling.

1. Remove the three Waste Ink Pads from the trays.

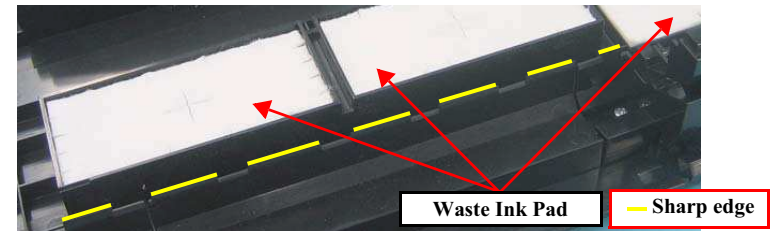

Figure 4-62. Removing the Waste Ink Pad



Insert the Waste Ink Pads into the trays inserting the slits of the pads over the tabs on the trays. Make sure to push the pads as far as they will go (until their top surface locate lower than the top surface of the tray edges).

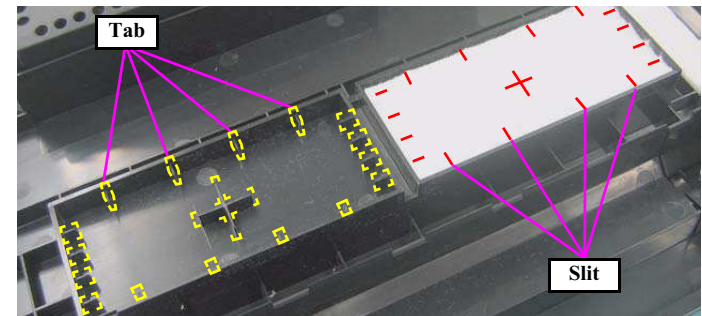

Figure 4-63. Installing the Waste Ink Pad



Whenever the Waste Ink Pad is replaced, the required adjustments must be carried out.

- Refer to "5.1.2 Required Adjustments" (p.99)

4.4.7 Left & Right Guide Stackers / CDR Guide Sensor

- Parts/Components need to be removed in advance
Printer Cover / Paper Support Assy / Upper Housing / Main Board Unit / Panel Assy / Cover Open Sensor / Printer Mechanism
- Removal procedure

CAUTION

Be careful of the seven sharp edges shown in Fig.4-64 when assembling or reassembling.

- Left / Right Guide Stacker Removal
 1. Remove the screw and remove the Left Guide Stacker.
 - Screw : C.B.P. M3x8 (tightening torque: 5-7 kgf.cm) (No.3)
 2. Remove the screw and remove the Right Guide Stacker.
 - Screw : C.B.P. M3x8 (tightening torque: 5-7 kgf.cm) (No.3)

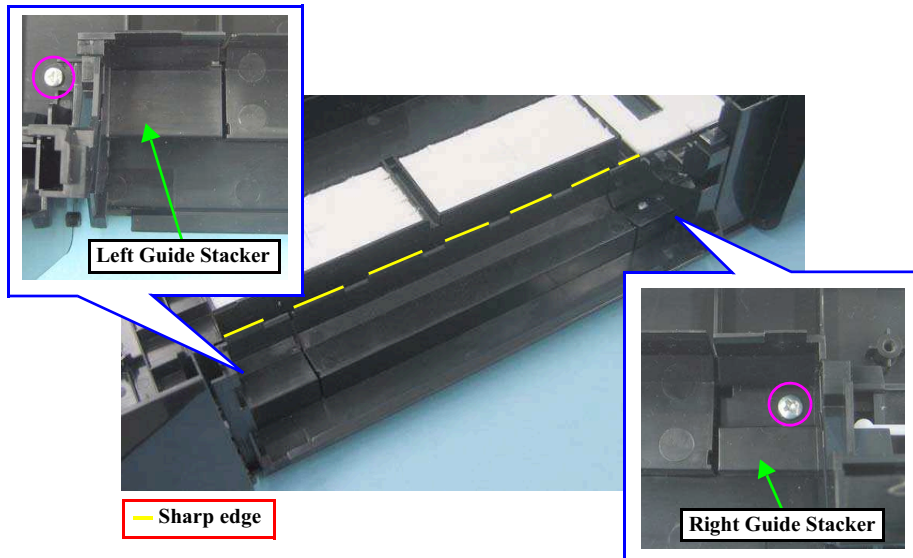

Figure 4-64. Removing the Left / Right Guide Stacker



- When installing the Left Guide Stacker, insert the rib indicated with in Fig.4-65 and match the positioning holes and guide pins indicated with (two pairs).
- When installing the Right Guide Stacker, match the positioning holes and guide pins indicated with (two pairs) in Fig.4-65.

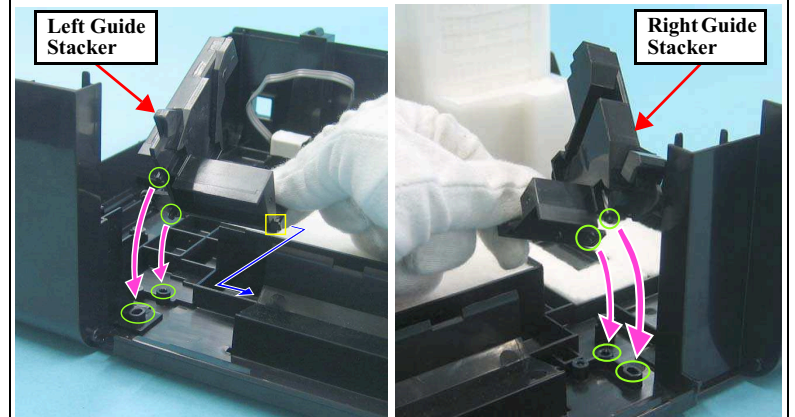

Figure 4-65. Installing the Left / Right Guide Stacker

- CDR Guide Sensor Removal
 1. Disengage the two hooks on the back of the CDR Guide Sensor and remove the CDR Guide Sensor.

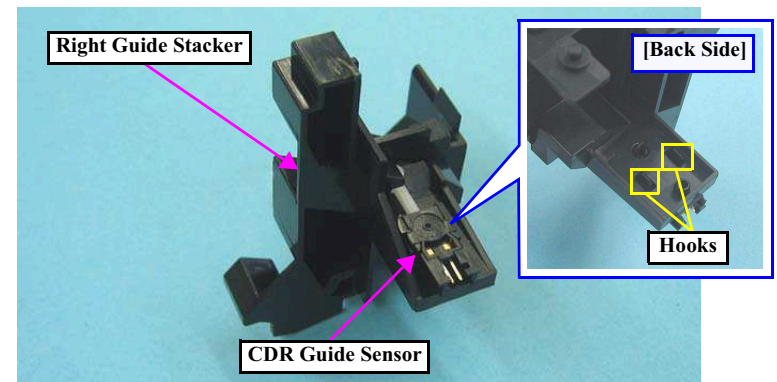

Figure 4-66. Removing the CDR Guide Sensor

4.4.8 Ink System



- Take extra care not to spill ink and contaminate the surroundings. Also, when removing the Waste Ink Tube, be careful not to spill the ink.
- Extra care must be taken to avoid injury from sharp edges of the rib of the Main Frame.
- Be careful not to drop and damage the shaft of the Carriage Lock and the Torsion Spring, as they easily come off.

Figure 4-67. Ink System

- Parts/Components need to be removed in advance
Printer Cover / Paper Support Assy / Upper Housing / Main Board Unit / Panel Assy / Cover Open Sensor / Printer Mechanism
- Removal procedure



See the section given below on how to unlock the carriage.

- “4.1.8 How to Unlock the Carriage”

1. Move the CR Unit to the center.
2. Remove the screw (1) that secures the Cap section.
 - Screw ○: C.B.S. M3x6 (tightening torque: 7-9 kgf.cm) (No.1)
(The numbers shown in the figure indicate the order of tightening the screws.)
3. Insert a screwdriver through the hole of the Main Frame and remove the screw (2) that secures the Pump section.
 - Screw ○: C.B.S. M3x6 (tightening torque: 7-9 kgf.cm) (No.1)
(The numbers shown in the figure indicate the order of tightening the screws.)

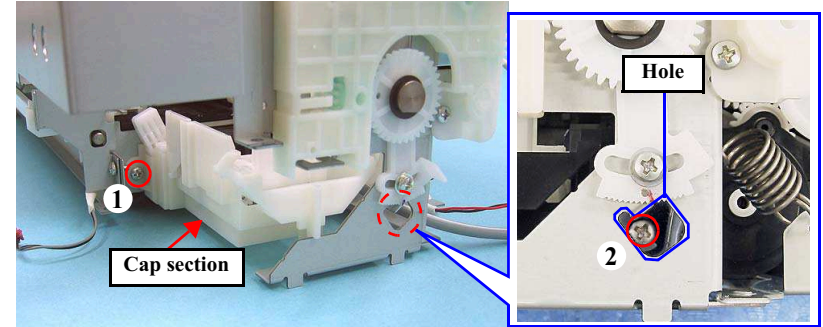

Figure 4-68. Removing the Ink System (1)

4. Slide the Ink System to the direction of the arrow and disengage the Ink System from the guide pin of the ASF Unit.

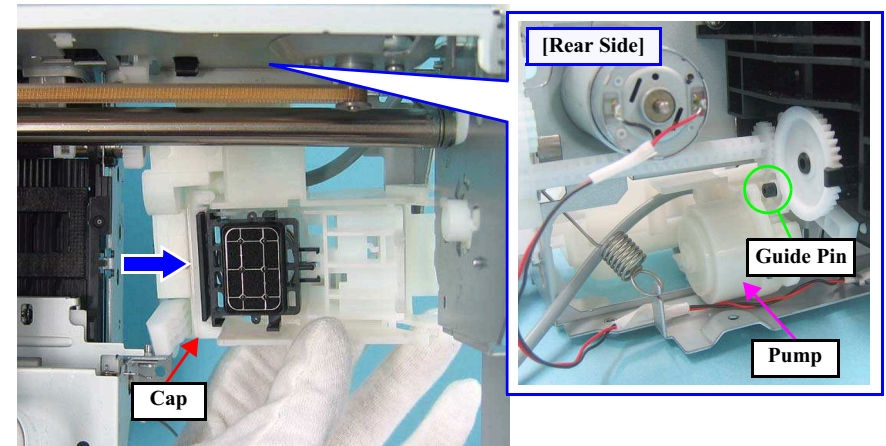

Figure 4-69. Removing the Ink System (2)

5. Remove the Ink System in the following procedures.
 1. Slide it to the right.
 2. Rotate it in the direction of the arrow (1) and release the pump part from the Main Frame.
 3. Pull it out toward you (arrow (2)).

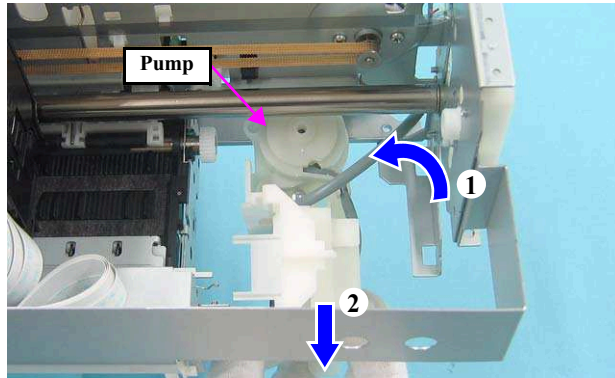

Figure 4-70. Removing the Ink System (2)



When installing the Ink System, be careful of the following:

- Lubrication is required. See the page given below for the lubrication information.
[Lubrication of Ink System \(p.117\)](#)
- Insert the shafts of the Ink System into the positioning holes (○) of the Frame.



Figure 4-71. Reinstalling the Ink System (1)

- Tighten the screws in the order given in [Fig.4-68](#).
- After installing the Ink System, check the Carriage Lock for proper operation referring to the section given below.
 - “4.1.8 How to Unlock the Carriage”
- Insert the positioning hole of the Ink System shown in [Fig.4-69](#) over the guide pin of the ASF Unit.

4.4.9 EJ Frame Assy

- Parts/Components need to be removed in advance
Printer Cover / Paper Support Assy / Upper Housing / Main Board Unit / Panel Assy / Cover Open Sensor / Printer Mechanism
- Removal procedure
 1. Move the CR Unit to the home position side.
 2. Release the Head FFC from the two hooks of the Cable Holder Frame and pull out the Head FFC through the cutout.
 3. Release the Head FFC from the three hooks of the Front Frame and peel off the double-sided tape.

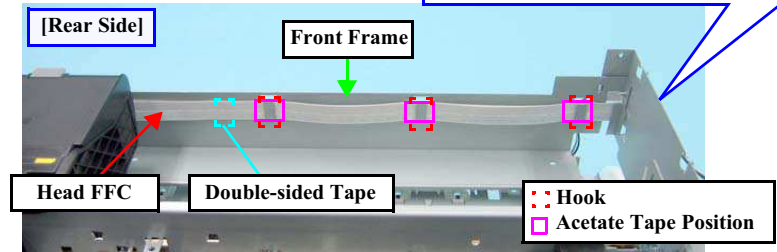
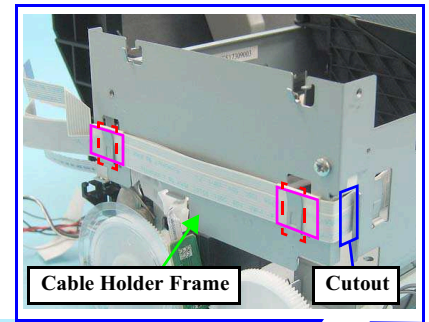



Figure 4-72. Removing the Head FFC

4. Disconnect the PF Encoder FFC from the PF Encoder.
5. Remove the two screws, disengage the two hooks of the Cable Holder Frame from the Front Frame and Main Frame, and remove the Cable Holder Frame.
6. Screw : C.B.S. M3x6 (tightening torque: 7-9 kgf.cm) (No.1)
(The numbers shown in the figure indicate the order of tightening the screws.)

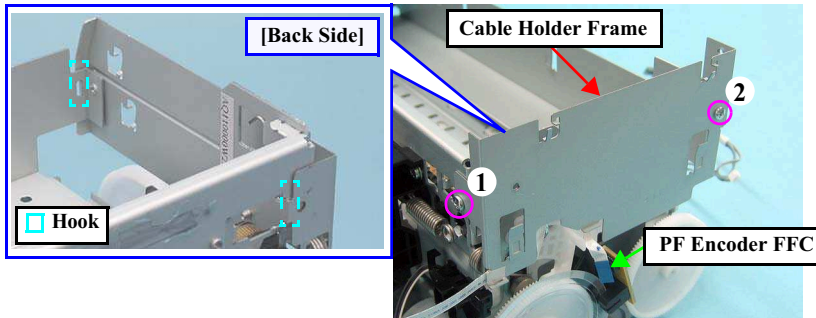

Figure 4-73. Removing the Cable Holder Frame

7. Peel off the PF Encoder FFC from the back of the Cable Holder Frame.

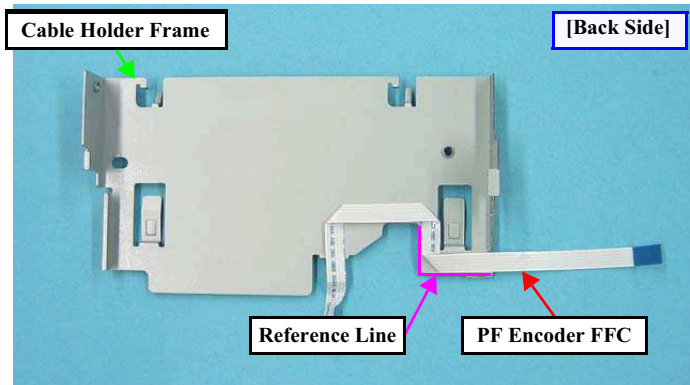



Figure 4-74. Removing the PF Encoder FFC

8. Remove the screws on the right and left sides, and remove the Front Frame.
 - Screw : C.B.S. M3x6 (tightening torque: 7-9 kgf.cm) (No.1)
(The numbers shown in the figure indicate the order of tightening the screws.)

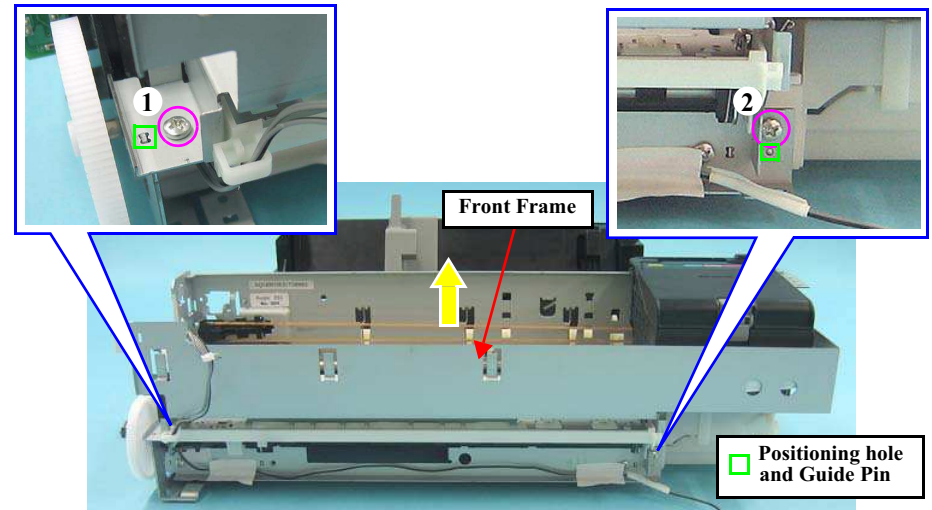

Figure 4-75. Removing the Front Frame

9. Release the CDR Sensor Cable from the cable guide of the EJ Frame Assy.
10. Remove the EJ Frame Assy.

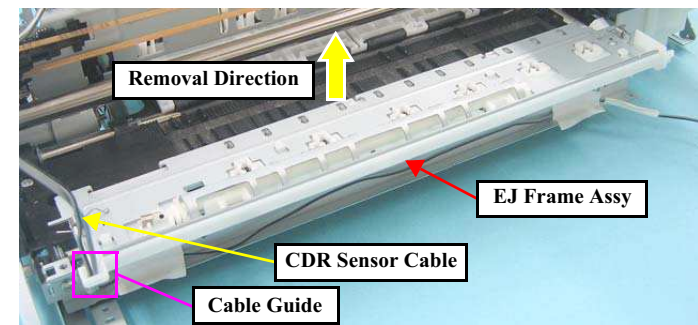

Figure 4-76. Removing the EJ Frame Assy



When installing the EJ Frame Assy, be careful of the following:

- Lubrication is required. See the page given below for the lubrication information.
[Lubrication of EJ Frame Assy \(p.115\)](#)
- As shown in [Fig.4-77](#), insert the two bearings of the EJ Frame Assy over the EJ Roller Shaft.

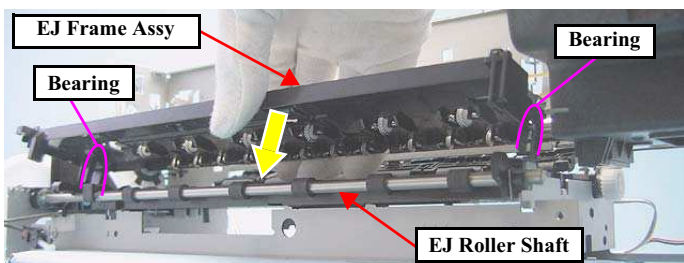

Figure 4-77. Reinstalling the EJ Frame Assy

- When installing the EJ Frame Assy, make sure that the Left/Right EJ Frame Springs are attached as shown in [Fig.4-78](#). Carefully handle the EJ Frame Assy as the springs come off easily.

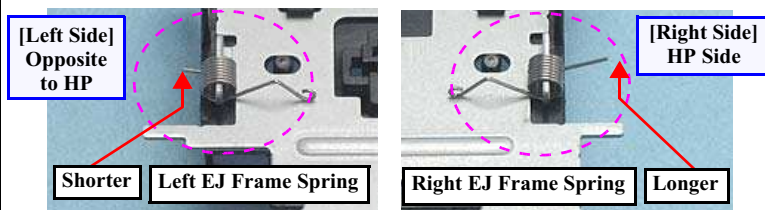

Figure 4-78. Reinstalling the Front Frame (1)



- When installing the Front Frame, screw it after securing the foot of the two EJ Frame Springs to the slits as shown in the figure. Carefully handle the EJ Frame as the springs come off easily.

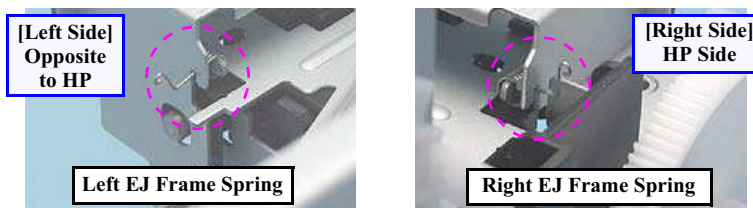

Figure 4-79. Reinstalling the Front Frame (2)

- When installing the Cable Holder Frame, match the two hooks of the Cable Holder Frame with the positioning holes of the Main Frame and Front Frame as shown in [Fig.4-73 \(p.81\)](#), and tighten the screws in the order given in the figure.
- When installing the Cable Holder Frame, attach the PF Encoder FFC along with the reference line shown in [Fig.4-74 \(p.81\)](#).
- When installing the Front Frame, match the positioning holes of the Front Frame with the guide pins of the Main Frame (two pairs), and tighten the screws in the order given in [Fig.4-75 \(p.81\)](#).



Whenever the EJ Frame Assy is removed or replaced, the required adjustments must be carried out.

- [Refer to "5.1.2 Required Adjustments" \(p.99\)](#)

DURAKLIN

4.4.10 PF Encoder / PF Scale



Take extra care not to contaminate or scratch the PF Scale. Never touch the scale with bare hands.

- ❑ Parts/Components need to be removed in advance
Printer Cover / Paper Support Assy / Upper Housing / Main Board Unit
- ❑ Removal procedure
 1. Disconnect the FFC of the PF Encoder from CN1 connector.
 2. Remove the screw and remove the PF Encoder.
 - Screw : C.B.P. M2.6x8 (tightening torque: 3.5-4.5 kgf.cm) (No.5)
 3. Peel off the double-sided tape attached to the center part, and remove the PF Scale.

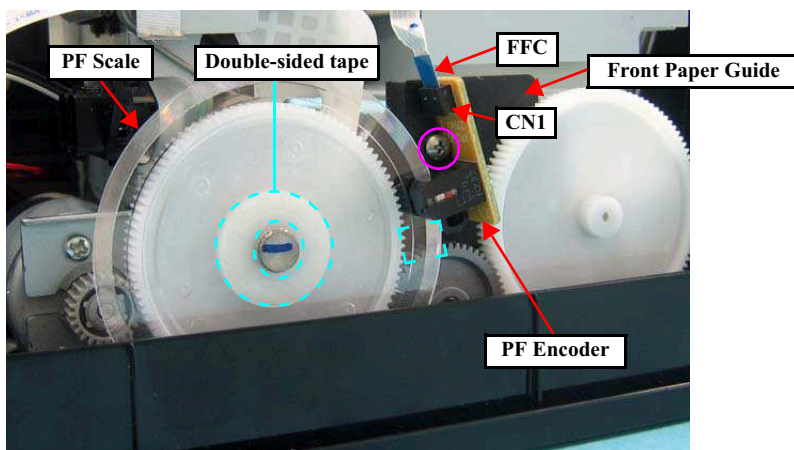

Figure 4-80. Removing the PF Encoder/PF Scale



When installing the PF Encoder, make sure the PF Encoder fits firmly against the Front Paper Guide.

4.4.11 PF Motor



Be careful not to damage the Pinion Gear of the PF Motor.

- ❑ Parts/Components need to be removed in advance
Printer Cover / Paper Support Assy / Upper Housing / Main Board Unit / Panel Assy / Cover Open Sensor / Printer Mechanism / PF Encoder / PF Scale
- ❑ Removal procedure
 1. Release the PF Motor Cable from the hook of the ASF Unit.
 2. Remove the two screws that secure the PF Motor.
 - Screw : C.P. M3x6 (tightening torque: 3-5 kgf.cm) (No.7)
(The numbers shown in the figure indicate the order of tightening the screws.)
 3. Slide the PF Motor to pull it out through the cutout and remove the PF Motor.

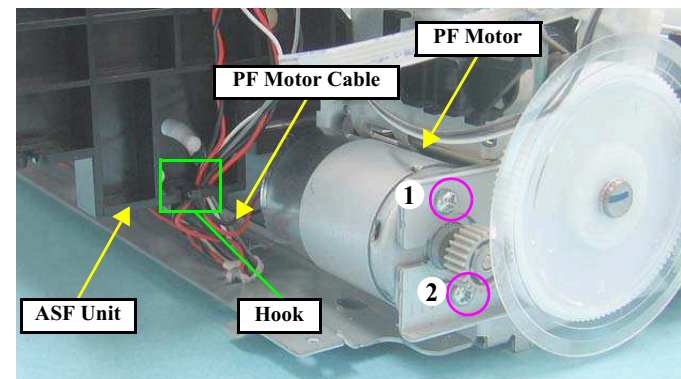

Figure 4-81. Removing the PF Motor



Whenever the PF Motor is replaced, the required adjustments must be carried out.

- Refer to "5.1.2 Required Adjustments" (p.99)

4.4.12 CR Motor

- Parts/Components need to be removed in advance
Printer Cover / Paper Support Assy / Upper Housing / Main Board Unit / Panel Assy / Cover Open Sensor / Printer Mechanism
- Removal procedure
 1. Remove the Extension Spring of the Driven Pulley Assy from the rear side.

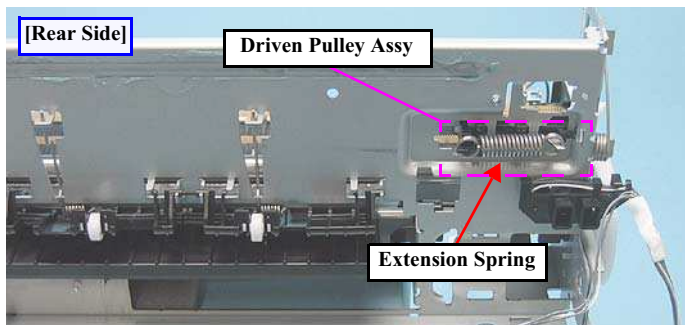

Figure 4-82. Removing the Extension Spring



Take extra care not to contaminate the Timing Belt with grease. The belt deteriorates faster if grease adheres to it.

2. Remove the Driven Pulley Assy and remove the Timing Belt from the Pinion Gear of the CR Motor.

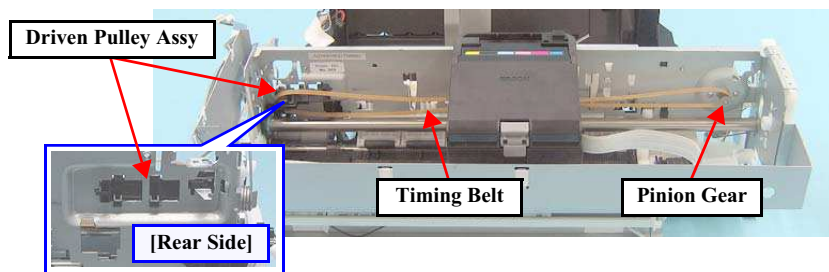

Figure 4-83. Removing the CR Motor (1)



When assembling or disassembling the CR Motor, be careful of the three sharp hooks of the Main Frame shown in Fig.4-84.

3. Release the connector cables from the three hooks, then peel off the three acetate tapes to release the CR Motor cable.

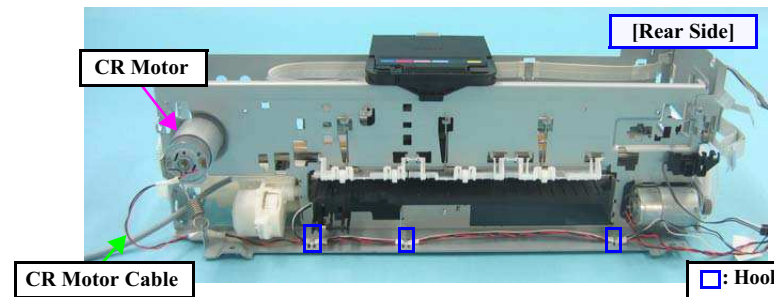

Figure 4-84. Removing the CR Motor (2)

4. Insert a Phillips screwdriver (with a shaft of 13cm or longer is recommended) through the hole of the Front Frame, remove the two screws, and remove the CR Motor.
 - Screw ○: C.P. M3x4 (tightening torque: 3-5 kgf.cm) (No.6)
(The numbers shown in the figure indicate the order of tightening the screws.)

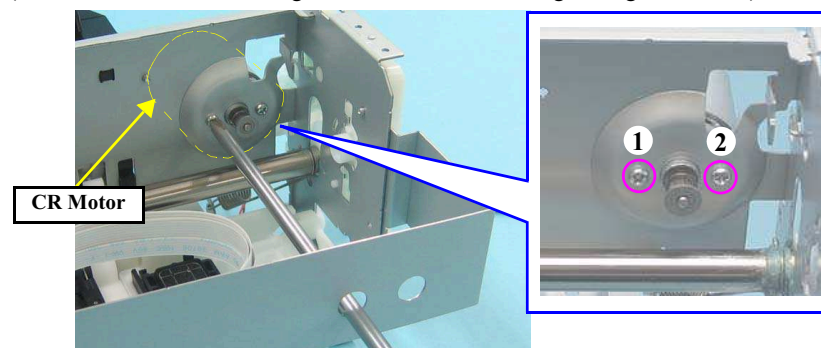

Figure 4-85. Removing the CR Motor (3)



- When routing the CR Motor Cable and PE Sensor Cable, refer to [Fig.4-86](#) and follow the steps below.
 1. Wrap the CR Motor Cable with the acetate tape A (30 mm) at the position of 100 mm away from the acetate tape that is on the CR Motor side.
 2. Tie the two cables together with the acetate tape B (20 mm) at the position 60mm/40mm away from the acetate tape A/ PE Sensor connector.
 3. Route the center of the acetate tape A behind the convex portion of the Main Frame, and secure the tied cables with the hook (1) at the center of the acetate tape B so that the CR Motor Cable faces toward you.
 4. Wrap the CR Motor Cable and PE Sensor Cable with acetate tapes (20 mm) at the positions of the hooks (2) (3), then secure the center of the acetate tapes with Hooks (2) (3).

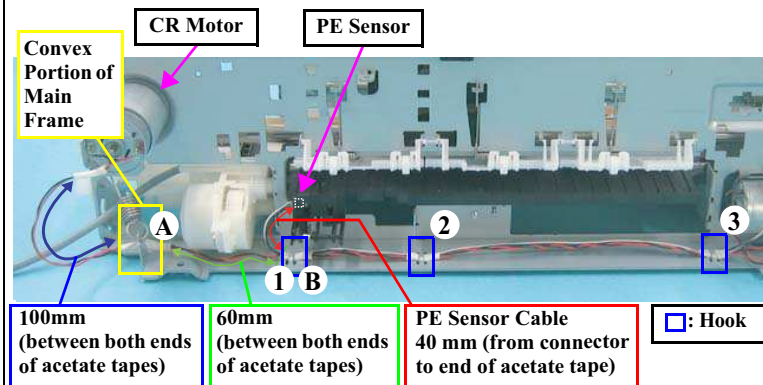

Figure 4-86. Routing the Cable



- Lubrication is required. See the page given below for the lubrication information.
 - [Lubrication of Driven Pulley \(p.114\)](#)
- When installing the CR Motor, install it so that the print side faces upwards.



Figure 4-87. Reinstalling the CR Motor



- Whenever the CR Motor is replaced, the required adjustments must be carried out.
 - [Refer to "5.1.2 Required Adjustments" \(p.99\)](#)

DURAKLIN

4.4.13 CR Unit

- Parts/Components need to be removed in advance
Printer Cover / Paper Support Assy / Upper Housing / Main Board Unit / Panel Assy / Cover Open Sensor / Printer Mechanism / APG Unit
- Removal procedure

CAUTION  Before turning the Parallelism Bushing L, mark the scale position of the Parallelism Bushing with a marker. And taking extra care not to damage the Gear with the rib, pull it toward the front.

1. Remove the Cable Holder Frame and Front Frame. (p.81)
2. Disengage the upper end of the Spring (1) from the slit, and remove the Spring (1).
3. Loosen the screw (○), and turn the Parallelism Bushing L clockwise to the maximum.

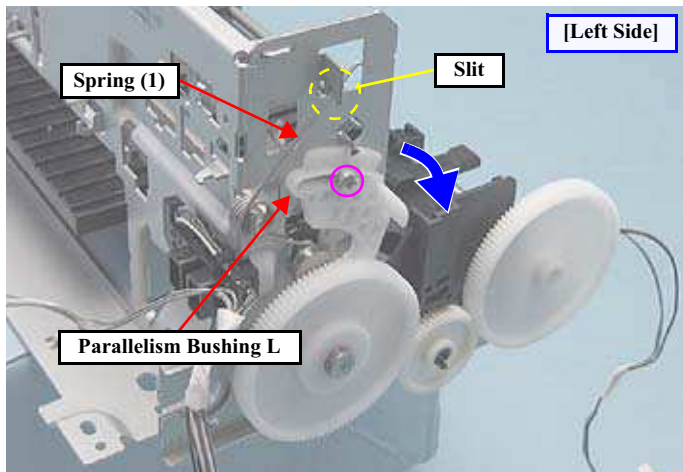

Figure 4-88. Removing the CR Unit (1)

4. Disengage the end of the Spring (2) from the hook, and the other end from the slit of the CR shaft, and remove the Spring (2).
5. Remove the washer by expanding the gap between the washer and the Right PG Cam using a pair of Tweezers, and remove the Right PG Cam.

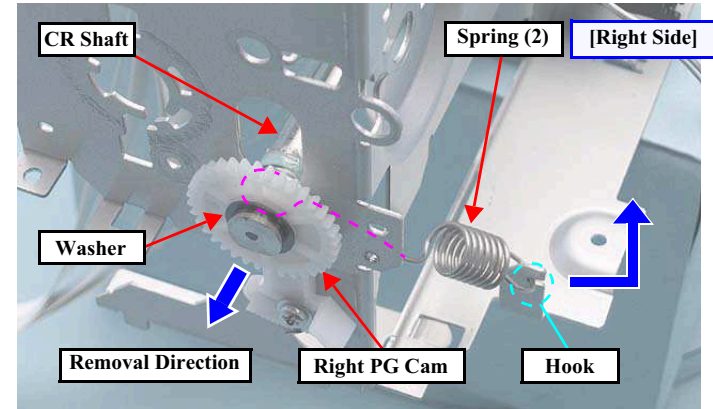



Figure 4-89. Removing the CR unit (2)

CAUTION  If the Print Head has not been removed, be extremely careful not to touch the nozzle surface of the Print Head.

6. Hold the CR Unit from the bottom and lift up the CR Shaft, release from the bushing in the (1) (2) order, and remove the CR Unit with the Shaft from the Main Frame.

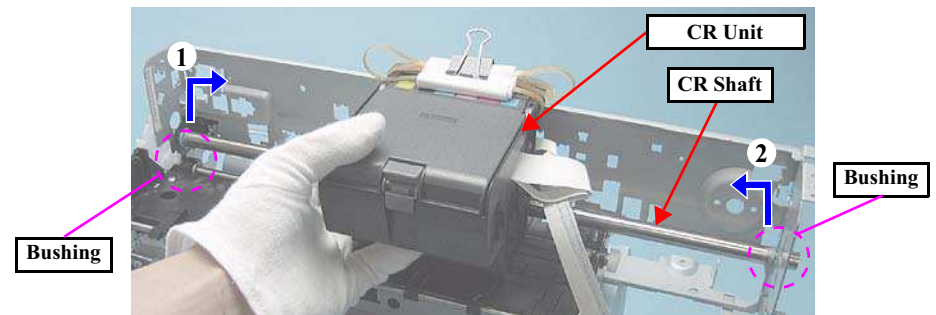

Figure 4-90. Removing the CR Unit (3)

7. Remove the CR Shaft from the CR Unit.



Figure 4-91. Removing the CR Unit (4)

8. Remove the Timing Belt from the CR Unit.

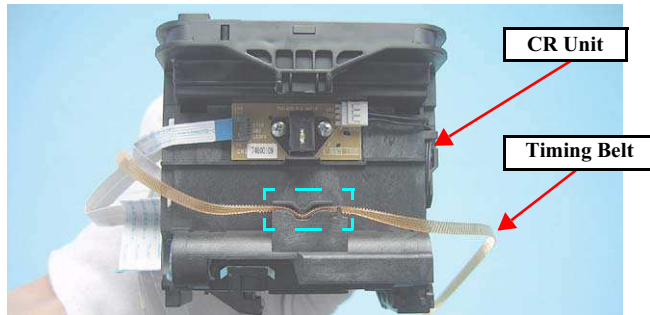

Figure 4-92. Removing the CR Unit (5)

9. Disconnect the FFC from the CR Encoder connector, pull out the FFC from the slit of the CR Unit, and remove the Head FFC.

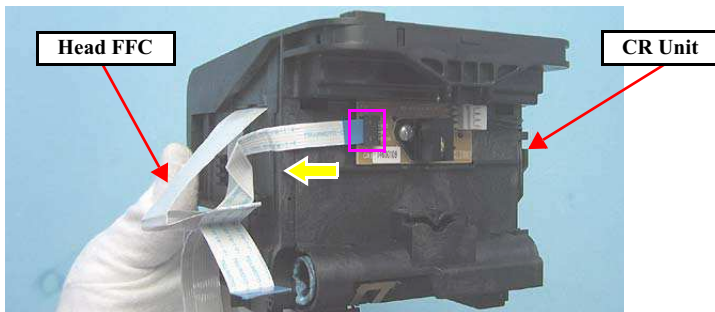

Figure 4-93. Removing the CR Unit (6)



- Lubrication is required. See the page given below for the lubrication information.
[Lubrication of CR Unit \(p.116\)](#)
- Before attaching the right PG cam, remove the APG Unit and install the cam matching its phase with the APG Unit. (Refer to Reinstalling the APG Unit (p.76))
- When attaching the spring (2) and the washer for the Right PG Cam to the CR Shaft, make sure to attach them to the positioning slits on the CR Shaft. (See Fig.4-89 (p.86))
- When installing the Timing Belt, make sure that it is not twisted and the lumpy side comes to the inner side.

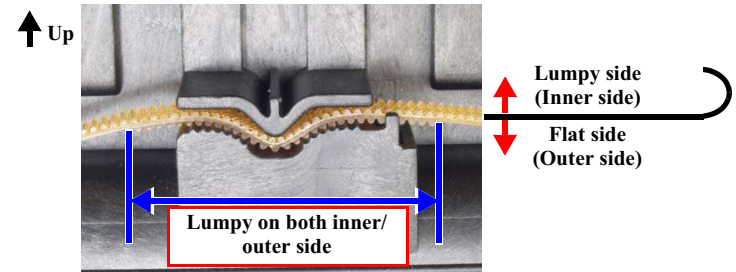

Figure 4-94. Reinstalling the Timing Belt

- When installing the CR Unit, hook the Guide part to the Main Frame.

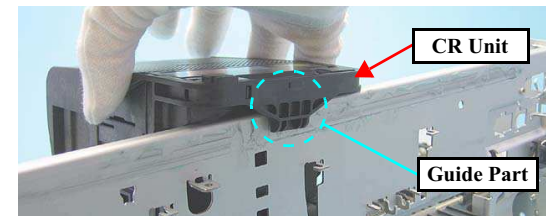

Figure 4-95. Reinstalling the CR Unit



- Whenever the CR Unit is removed or replaced, the required adjustments must be carried out.
- Refer to "5.1.2 Required Adjustments" (p.99)



Remove the Cartridge Cover following the steps below. The Hinge, Cover Cartridge need to be cut with a nipper or similar tool to be removed. Therefore, whenever replacing the Cartridge Cover, the Hinge, Cover Cartridge also must be replaced with a new one.

1. Cut the convex portion of the Hinge, Cover Cartridge with a nipper or similar tool.
2. Disengage the hook from the opening made by the cut and remove the Hinge, Cover Cartridge.
3. Remove the Cartridge Cover pulling out its two guide pins.

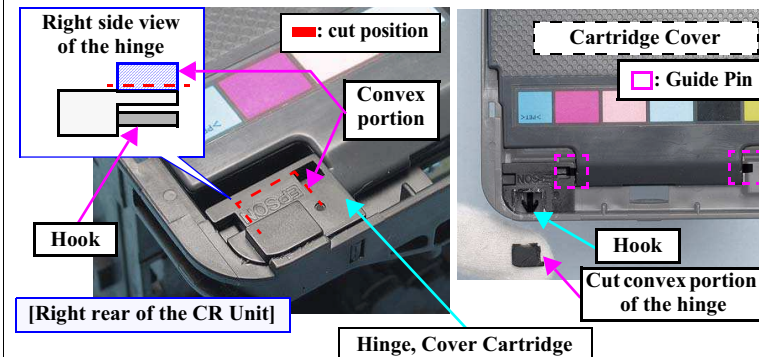

Figure 4-96. Removing the Cartridge Cover

4.4.14 ASF Unit

- Parts/Components need to be removed in advance
Printer Cover / Paper Support Assy / Upper Housing / Main Board Unit / Panel Assy / Cover Open Sensor / Printer Mechanism / Ink System
- Removal procedure
 - Removing the LD Roller Guide
 1. Move the CR Unit to the left (the opposite side to the home position).
 2. Remove the screw that secures the LD Roller Guide.
 - Screw ○ : C.B.S. (P4), M3x6 (tightening torque: 7-9 kgf.cm) (No.8)



When performing the following steps, be careful not to damage the hooks of the LD Roller Guide.

3. Push the tabs on the right and the left, slide the LD Roller Guide upward to remove it disengaging the five hooks.

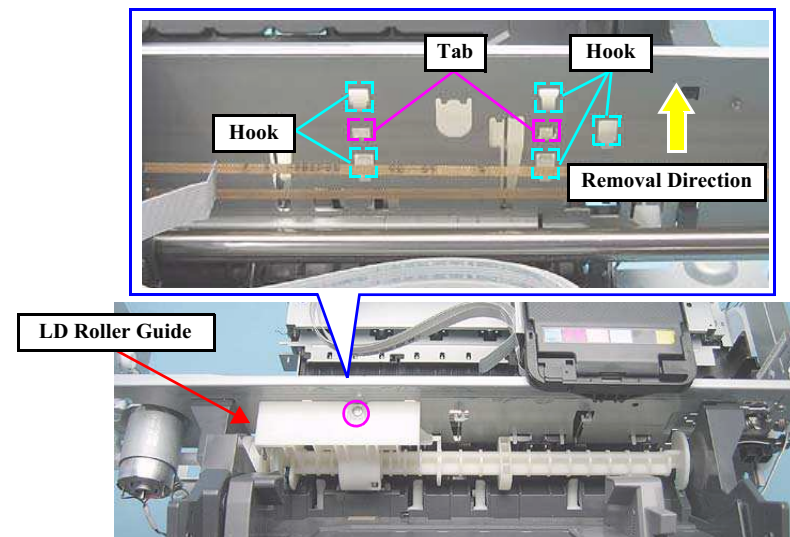

Figure 4-97. Removing the LD Roller Guide (1)

- Remove the Torsion Spring 137.7 from the LD Roller Guide.

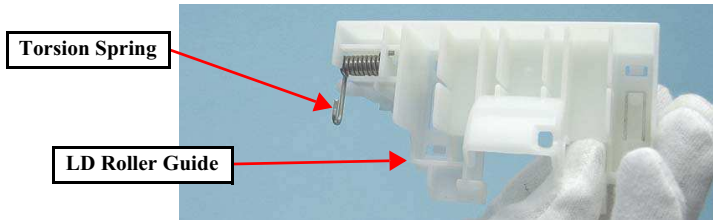

Figure 4-98. Removing the LD Roller Guide (2)

■ Removing the ASF Unit

- Release the following cables from the ASF Unit.

- CR Motor Cable
- PF Motor Cable
- PE Motor Cable

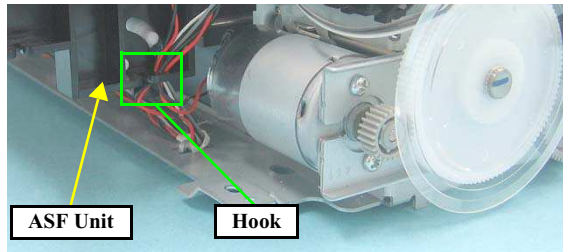



Figure 4-99. Releasing the Cables

- Remove the two screws on the rear side.

- Screw  : C.B.S.(P4), M3x6
(tightening torque: (1) 7-9 kgf.cm, (2) 9-11 kgf.cm) (No.8)
(The numbers shown in the figure indicate the order of tightening the screws.)

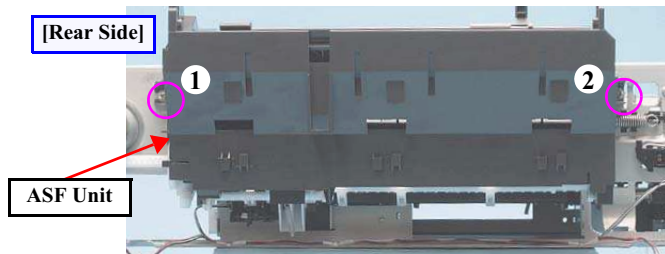

Figure 4-100. Disengaging the Hooks (ASF Unit)

- Disengage the two hooks (1) (2) that secure the ASF Unit from the Main Frame.
- Remove the Combination Gear (10,15.2), then remove the ASF Unit while releasing the edge of the Change Lever from the hole of the Main Frame.

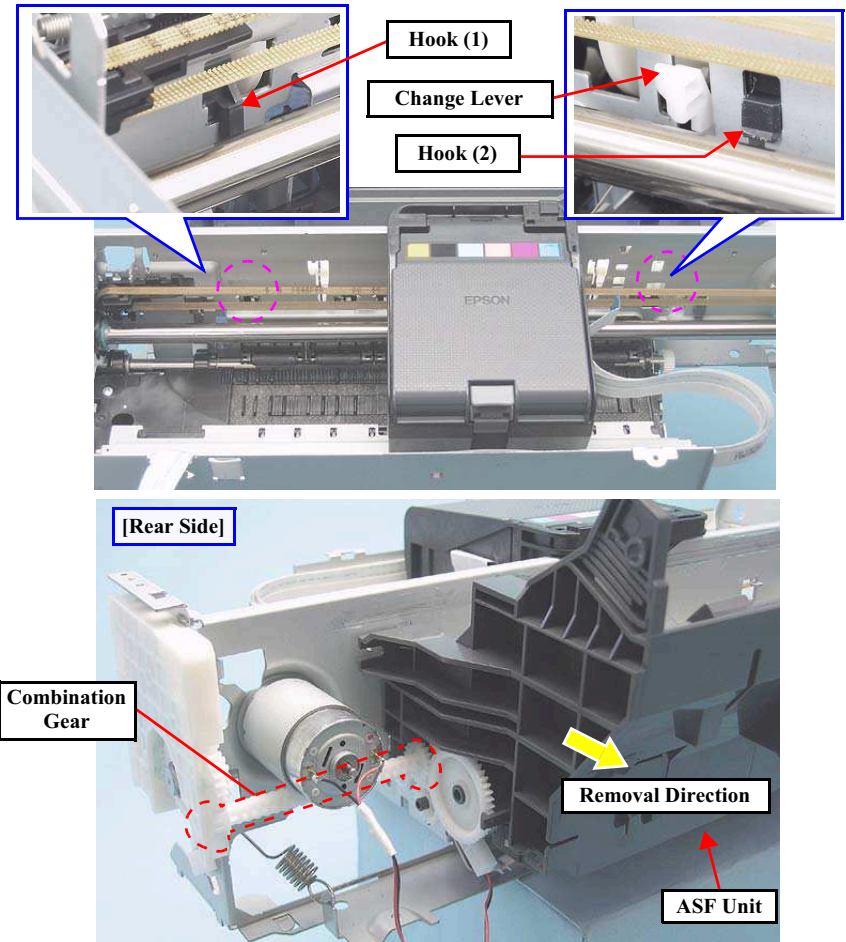

Figure 4-101. Removing the ASF Unit



- Lubrication is required. See the page given below for the lubrication information.
[Lubrication of ASF Unit \(p.118\)](#)
 - When installing the ASF Unit, make sure that the Combination Gear, tip of the Change Lever and the two hooks are securely attached. Also make sure that there is appropriate space at both the left and right of the Change Lever.
 - Tighten the screws in the order given in [Fig.4-100 \(p.89\)](#).
 - Install the LD Roller following the procedure below. Make sure to apply grease referring to the page given below.
[Lubrication of the ASF Unit \(p.118\)](#)
1. Install the LD Roller aligning the arrow on the LD Roller with the arrow on the blade of the shaft. Make sure the LD Roller is securely attached without gap or misalignment.

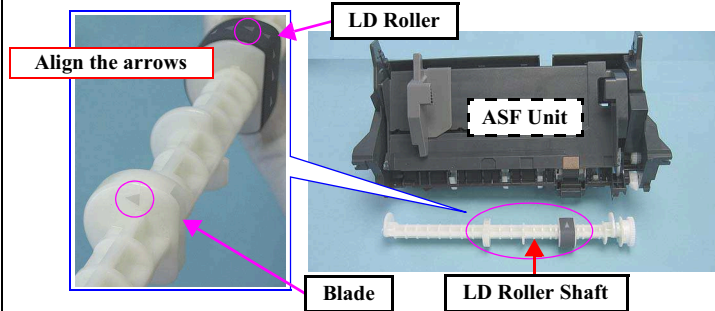

Figure 4-102. Reinstalling the LD Roller



- Whenever the ASF Unit is removed or replaced, the required adjustments must be carried out.
- Refer to "5.1.2 Required Adjustments" (p.99)

4.4.15 Upper Paper Guide



- Be sure to follow the procedure below to remove the Upper Paper Guide to avoid damaging the PE Sensor Lever.
- It is recommended to place a transparent sheet between the Upper and Front Paper Guides to avoid scratching the roller.
- Do not touch the roller surface with bare hands as it can adversely affect the print quality.

- Parts/Components need to be removed in advance
Printer Cover / Paper Support Assy / Upper Housing / Main Board Unit / Panel Assy / Cover Open Sensor / Printer Mechanism / Ink System / ASF Unit
- Removal procedure
 1. Remove the three springs from the rear side, disengage the three hooks and remove the Upper Paper Guide from the Main Frame.

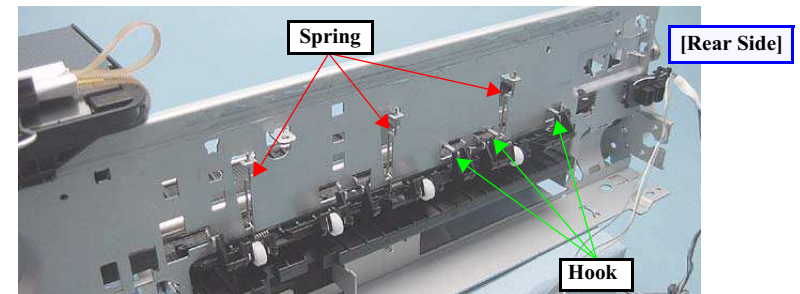



Figure 4-103. Removing the Upper Paper Guide (1)

2. Remove the Upper paper Guide pressing  part to lower the tip of the PE Sensor Lever.

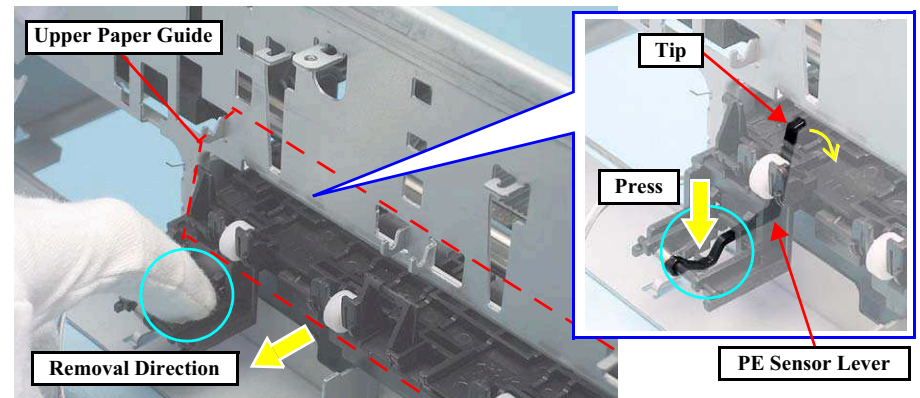
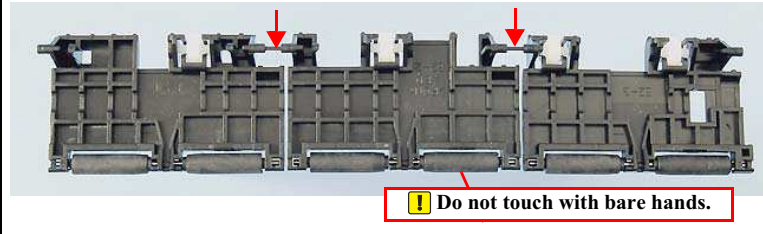

Figure 4-104. Removing the Upper Paper Guide



The figure below is the Upper Paper Guide. The two thin shafts indicated with the arrows are likely to break, however, the Upper Paper Guide does not need to be replaced even if the shafts become broken. Because the shafts do not go on the bushings of the Printer Frame.



When installing the three springs, secure the ends of the springs on the hooks of the Main Frame as shown in Fig.4-105.

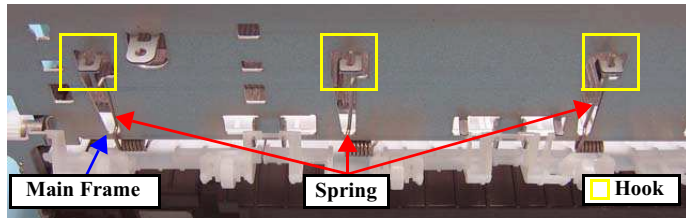

Figure 4-105. Installing the Springs



Whenever the Front Paper Guide Assy is removed or replaced, the required adjustments must be carried out.

- Refer to "5.1.2 Required Adjustments" (p.99)

4.4.16 APG Sensor Assy

- Parts/Components need to be removed in advance
Printer Cover / Paper Support Assy / Upper Housing / Main Board Unit
- Removal procedure
 1. Disengage the two hooks and remove the APG Sensor Assy.

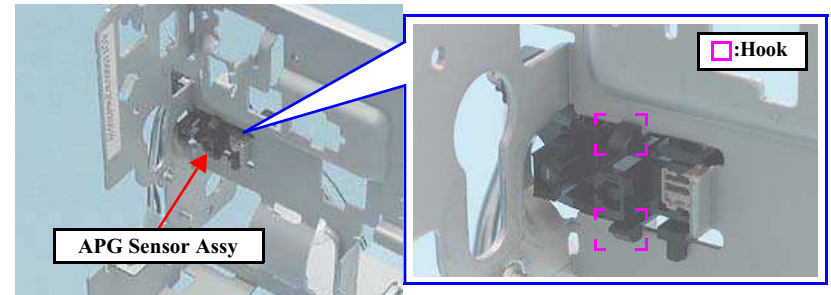

Figure 4-106. Removing the APG Sensor

DURAKLIN

4.4.17 Front Paper Guide Assy



Do not touch the surface of the rubber roller of the EJ Roller Assy and the coated part of the PF Roller Assy as it can adversely affect the print quality.

- Parts/Components need to be removed in advance
 Printer Cover / Paper Support Assy / Upper Housing / Main Board Unit / Panel Assy / Cover Open Sensor / Printer Mechanism / Ink System / CR Motor / PF Encoder / PF Scale / PF Motor / EJ Frame Assy / APG Unit / CR Unit / ASF Unit / Upper Paper Guide
- Removal procedure
 1. Remove the screw and remove the Parallelism Bushing L.
 - Screw ○ : C.B.S.(P2) M3x8 (tightening torque: 6-8 kgf.cm) (No.9)

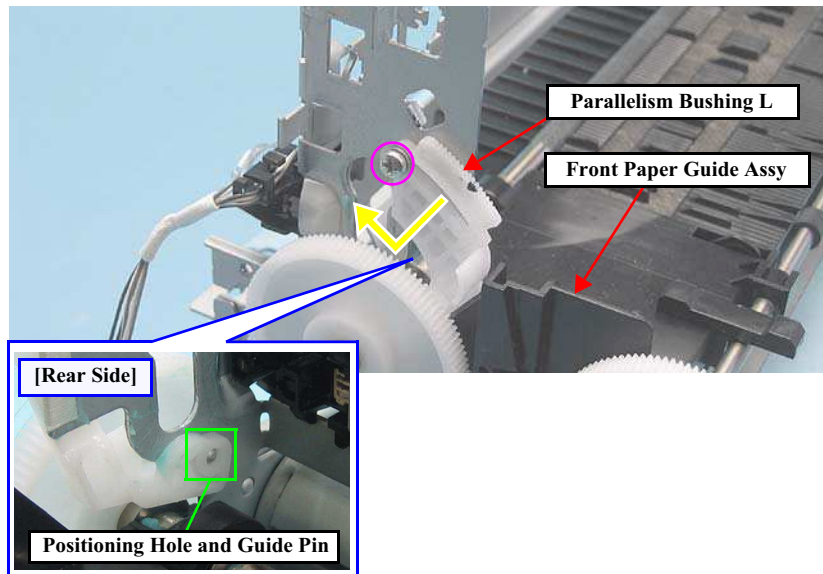

Figure 4-107. Removing the Parallelism Bushing L

2. Disconnect the connector of the PE Sensor Cable on the rear side of the printer.
3. Remove the screw that secures the Front Paper Guide Assy.
 - Screw ○ : C.B.S. M3x6 (tightening torque: 7-9 kgf.cm) (No.1)

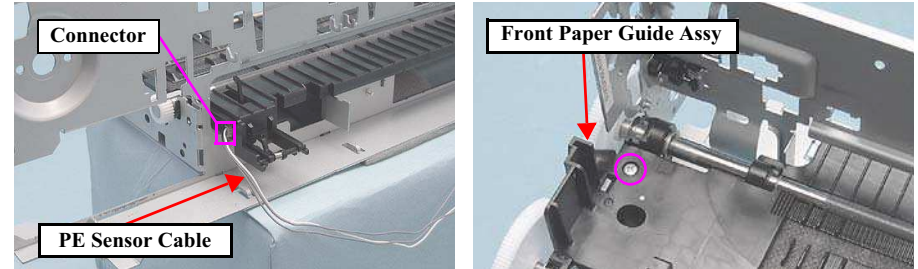

Figure 4-108. Removing the PE Sensor Cable

4. Pull out the EJ Ground Spring to the front side.

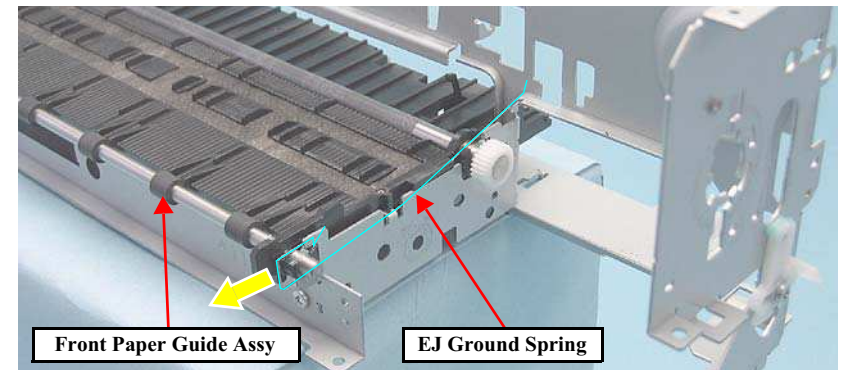



Figure 4-109. Removing the EJ Ground Spring

5. Remove the Front Paper Guide Assy, following the steps below.
 - (1) Lift  part to disengage the left side of the Front Paper Guide Assy.
 - (2) Slide the assy leftward little by little to disengage the right side of the assy.
 - (3) Remove the Front Paper Guide Assy while releasing its shaft from the cutout of the rib on the left side of the Main Frame.

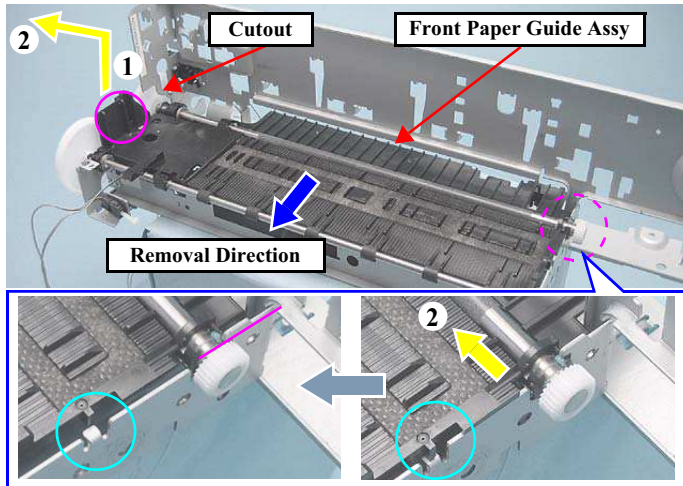

Figure 4-110. Removing the Front Paper Guide Assy



- Lubrication is required. See the page given below for the lubrication information.
[Lubrication of Front Paper Guide Assy \(p.115\)](#)



- When installing the Front Paper Guide Assy, pull out the CDR Tray Sensor cable as shown below.



Figure 4-111. Routing the CDR Tray Sensor Cable

- Attach the long foot of the EJ Ground Spring as follows; (1) put it through the gap under the portion contacts with the EJ Roller, (2) let it contact with the Main Frame, (3) let it contact with the PF Roller shaft, (4) put it through the hole on the frame. When finished, make sure the spring properly contacts with (1), (2), (3), and (4) points.

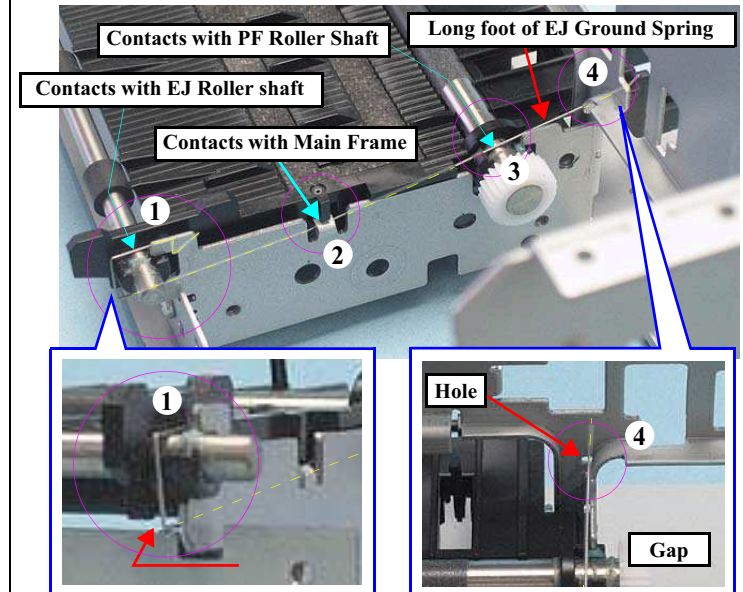

Figure 4-112. Attaching the EJ Ground Spring

- Be careful not to deform the EJ Ground Spring.

DURAKLIN



■ Place the four tips of the Front Paper Guide Pad on the Waste Ink Pad.

[Bottom Side]

Waste Ink Pad Position

Tip of Front Paper Guide Pad

Tip

Tip

Figure 4-113. Installing Front Paper Guide Pad

■ When installing Parallelism Bushing L, match the positioning hole with the guide pin shown in Fig.4-107 (p.92).



Whenever the Front Paper Guide Assy is removed or replaced, the required adjustments must be carried out.

- Refer to "5.1.2 Required Adjustments" (p.99)

4.4.18 CDR Tray Sensor

- Parts/Components need to be removed in advance
Printer Cover / Paper Support Assy / Upper Housing / Main Board Unit / Panel Assy / Cover Open Sensor / Printer Mechanism / Ink System / CR Motor / PF Encoder / PF Scale / PF Motor / EJ Frame Assy / APG Unit / CR Unit / ASF Unit / Upper Paper Guide / Front Paper Guide Assy
- Removal procedure



Always follow the steps below to remove the CDR Tray Sensor, or one of its hooks can be broken.

1. Disengage the hook of the CDR Tray Sensor.
2. Turn the CDR Tray Sensor 90 degrees in the direction of the arrow to disengage its another hook, and pull it out from the hole to remove it together with the CDR Guide Sensor.

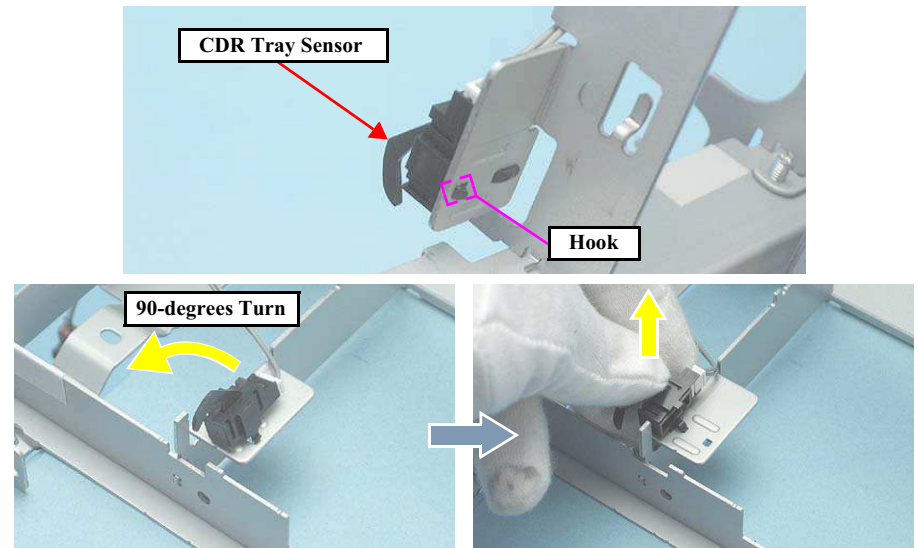

Figure 4-114. Removing the CDR Tray Sensor

ADJUSTMENT

CHAPTER

5

5.1 Adjustment Items and Overview

This chapter describes adjustments necessary after the disassembly/reassembly of the printer.

5.1.1 Servicing Adjustment Item List

The adjustment items of this product are as follows.



For information on how to carry out the adjustments and media required for the adjustments, see the instructions displayed by the Adjustment Program.

Table 5-1. Adjustment Items

Adjustment Item	Purpose	Method Outline	Tool
PG adjustment	Install the Head Nozzle surface parallel to the printing surface and set the gap between the paper and the Head Nozzle surface to the specified value.	Mechanical adjustment using the thickness gauges. Make a proper adjustment according to the result whether the manually-moved carriage (printhead) runs over or hits against the gauges placed on the platen.	• Thickness Gauge 1.15mm, 1.3mm
EEPROM data copy	When the main board needs to be replaced, use this to copy adjustment values stored on the old main board to the new board. If this copy is completed successfully, all the other adjustments required after replacing the main board are no longer necessary.	Readout the EEPROM data from the main board before removing it. Then replace the board with a new one, and load the EEPROM data to the new board.	• Adjustment Program
Initial setting	This must be carried out after replacing the main board to apply settings for the target market.	Select the target market. The selected market settings are automatically written to the main board.	• Adjustment Program
Head ID input	This must be carried out after replacing the printhead in order to enter the new printhead ID (Head ID) that reduces variation between printheads.	Enter the ID printed on the Head QR code label attached on the printhead. The correction values are automatically written to the main board.	• Adjustment Program
USB ID input	Sets a USB ID of the printer. A computer identifies the printer by the ID when multiple same models are connected via a USB hub.	Enter the product serial number of the printer. The ID is automatically generated and written to the main board.	• Adjustment Program
Initialize PF deterioration offset	Resets the counter to maintain paper feed accuracy which decreases due to paper dust.	Reset the counter to its default.	• Adjustment Program
Disenable PF deterioration offset	When reading the counter value from the old main board is impossible in the case of replacing the board, use this to set the counter to its maximum value.	Set the counter to its maximum value (3000).	• Adjustment Program
TOP margin adjustment	This corrects top margin of printout.	A top margin adjustment pattern is printed. Examine the lines printed near the top edge of the printout, and enter the value for the line that is exactly 3 mm away from the top edge.	• Adjustment Program • Ruler
Head angular adjustment	This must be carried out after replacing the printhead in order to correct tilt of the printhead by software.	A head angular adjustment pattern is printed. Examine the printed lines and enter the value for the most straight lines.	• Adjustment Program

Table 5-1. Adjustment Items

Adjustment Item	Purpose	Method Outline	Tool
Bi-D adjustment	Corrects print start timing in bi-directional printing to improve the print quality.	A Bi-D adjustment pattern is printed. Examine the patterns and enter the value for the pattern with no gap and overlap for each mode.	• Adjustment Program
First dot position adjustment	Corrects left margin of printout. The print start position in the carriage moving direction is corrected by software.	A first dot adjustment pattern is printed. Examine the lines printed near the left edge of the printout and enter the value for the line that is exactly 5 mm away from the left edge.	• Adjustment Program • Ruler
PW adjustment	This adjustment is made to correct the mounting position of the PW Sensor on a software basis to adjust the detection position and Nozzle position dispersion.	A PW adjustment pattern is printed. Examine the printout patterns and enter the value for the line that is exactly 5mm away from the paper edge for each of the left, right, top and bottom.	• Adjustment Program
PF adjustment	Corrects variations in paper feed accuracy when using the Microweave to achieve higher print quality.	A PF adjustment pattern is printed. Examine the printout patterns and select the value for the best pattern. The correction value is registered.	• Adjustment Program
BRS/PFP adjustment	This adjustment is made to ensure high print quality at high print speed. For more details, see “2.3 Banding Reduction System (BRS) / Paper Feed Amount Profile Correction (PFP) (p.26)	Print the adjustment pattern to be scanned by a specified scanner. According to the scanned result, a correction value is automatically calculated and stored into the serial flash ROM on the main board. The correction value is applied when printing in the corresponding mode.	• Specified Scanner • PFP base scale
CR motor heat protection control	This must be carried out for efficient heat control of the CR motor. Electrical variation of the motor and the power supply board are measured to acquire correction values for them.	Select the parts that you replaced. The correction values are automatically written to the main board.	• Adjustment Program

Table 5-2. Maintenance Items

Maintenance Item	Purpose	Method Outline	Tool
Head cleaning	This function is used to execute Cleaning efficiently when ink is not delivered from the Head properly, e.g. dot missing.	The head cleaning is performed automatically. After the cleaning, print a nozzle check pattern to check if all nozzles are firing ink properly.	• Adjustment Program
Waste ink pad counter	The printer causes a maintenance error when the waste ink pad counter reaches its maximum. Use this to reset the counter after replacing the Waste Ink Pad. If you find the counter is close to the maximum during servicing, carry out the pad replacement and the counter reset to avoid the printer returned from the user due to the maintenance error.	After replacing the Waste Ink Pad, reset the counter to its default.	• Adjustment Program
Ink charge	This must be carried out after replacing the printhead in order to fill ink inside the new printhead. The printhead becomes ready for print.	Filling ink inside the printhead is automatically performed. Print a nozzle check pattern to check if all nozzles are firing ink properly.	• Adjustment Program

Table 5-3. Additional Functions

Additional Functions		Purpose	Method Outline	Tool
Final check pattern print	A4 size	Use this to check if the all adjustments have been properly made.	The all adjustment patterns are printed automatically.	• Adjustment Program
	US Letter size			
EEPROM dump		Use this to readout the EEPROM data for analysis.	The all EEPROM data is automatically readout and stored as a file.	• Adjustment Program
Printer information check	Manual CL counter	Use this to readout information on the printer operations.	The printer information is automatically readout.	• Adjustment Program
	I/C exchange CL counter			
	Timer CL counter			
	Print path counter			

5.1.2 Required Adjustments

The table below lists the required adjustments depending upon the parts being repaired or replaced. Find the part(s) you removed or replaced, and check which adjustment(s) must be carried out.

Note : <Meaning of the marks in the table>

“O” indicates that the adjustment must be carried out. “O*” indicates that the adjustment is recommended. “--” indicates that the adjustment is not required.

If you have removed or replaced multiple parts, make sure to check the required adjustments for the all parts. And when multiple adjustments must be carried out, be sure to carry out them in the order given in the “Priority” row.

Table 5-4. Adjustment Items

Priority		1	2	3	4	5	6	7	8	9	10	11	12	13	14	15	16	17
Part Name	Adjustment Item	PG adjustment	EEPROM data copy	Initial setting	USB ID input	Head ID input	Waste ink pad counter	Ink charge	Initialize PF deterioration offset	Disenable PF deterioration offset	Top margin adjustment	Head angular adjustment	Bi-D adjustment	First dot position adjustment	PW adjustment	PF adjustment	BRS/PPP adjustment	CR motor heat protection control
	ASF Unit	Remove	--	--	--	--	--	--	--	--	--	O	--	--	O	--	O	O
Replace		--	--	--	--	--	--	--	--	--	O	--	--	O	--	O	O	--
CR Motor	Remove	--	--	--	--	--	--	--	--	--	--	--	O*	O*	--	--	--	--
	Replace	--	--	--	--	--	--	--	--	--	--	--	O*	O	--	--	--	O
Upper Paper Guide	Remove	--	--	--	--	--	--	--	--	--	O	--	--	--	--	O	O	--
	Replace	--	--	--	--	--	--	--	--	--	O	--	--	--	--	O	O	--
Printhead	Remove	O	--	--	--	--	--	--	--	--	O	O	O	O	O	O	O	--
	Replace	O	--	--	--	O	--	O	--	--	O	O	O	O	O	O	O	--
Main Board	Remove	--	--	--	--	--	--	--	--	--	--	--	--	--	--	--	--	--
	Replace (Read OK)	--	O	--	--	--	--	--	--	--	--	--	--	--	--	--	--	O
	Replace (Read NG)	--	--	O	O	O	O (Ink Pads must be replaced)	--	--	O	O	O	O	O	O	O	O	O
PS Board	Remove	--	--	--	--	--	--	--	--	--	--	--	--	--	--	--	--	--
	Replace	--	--	--	--	--	--	--	--	--	--	--	--	--	--	--	--	O

Table 5-4. Adjustment Items

Priority		1	2	3	4	5	6	7	8	9	10	11	12	13	14	15	16	17	
Adjustment Item	Part Name	PG adjustment	EEPROM data copy	Initial setting	USB ID input	Head ID input	Waste ink pad counter	Ink charge	Initialize PF deterioration offset	Disable PF deterioration offset	Top margin adjustment	Head angular adjustment	Bi-D adjustment	First dot position adjustment	PW adjustment	PF adjustment	BRS/PPF adjustment	CR motor heat protection control	
		Front Paper Guide Assy (including PF Shaft)	Remove	O	--	--	--	--	--	--	--	--	O	O	O	O	O	O	O
Replace	O		--	--	--	--	--	--	--	O	O	O	O	O	O	O	O	O	--
PF Motor	Remove	--	--	--	--	--	--	--	--	--	--	--	--	--	--	O*	O*	--	
	Replace	--	--	--	--	--	--	--	--	O	--	--	--	--	--	O	O	--	
Waste Ink Tray	Remove	--	--	--	--	--	--	--	--	--	--	--	--	--	--	--	--	--	
	Replace	--	--	--	--	--	O (Waste Ink Tray)	--	--	--	--	--	--	--	--	--	--	--	
Waste Ink Pad	Remove	--	--	--	--	--	--	--	--	--	--	--	--	--	--	--	--	--	
	Replace	--	--	--	--	--	O (Waste Ink pad)	--	--	--	--	--	--	--	--	--	--	--	
CR Unit	Remove	O	--	--	--	--	--	--	--	--	O	O	O	O	O	O	O	O	--
	Replace	O	--	--	--	--	--	--	--	--	O	O	O	O	O	O	O	O	--
Paper Eject Frame Assy	Remove	--	--	--	--	--	--	--	--	--	--	--	--	--	--	O	O	--	
	Replace	--	--	--	--	--	--	--	--	--	--	--	--	--	--	O	O	--	
Printer Mechanism	Remove	--	--	--	--	--	--	--	--	--	--	--	--	--	--	--	--	--	
	Replace	O	--	--	--	--	--	--	O	--	O	O	O	O	O	O	O	O	

DURAKLIN

5.2 Using the Adjustment Program

This section describes how to judge the adjustment patterns printed by the Adjustment Program. For information on how to operate the Adjustment Program, see the instructions displayed by the Adjustment Program.

5.2.1 Top Margin Adjustment

Patterns are printed as shown below.

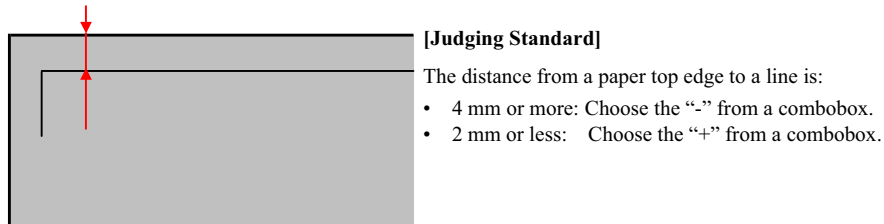

Figure 5-1. Top Margin Adjustment Pattern

How to Judge

Measure the distance from the top edge of paper to the printed line, and enter any one of the “-”, “0”, “+” according to the judging standard.

5.2.2 Head Angular Adjustment

Two patterns are printed as shown below.

□ Band pattern

The following pattern is printed. The lines below “0 >> 80” are printed while the carriage moves from the home to the other side, and lines below “80 >> 0” are printed while the carriage returns to the home.

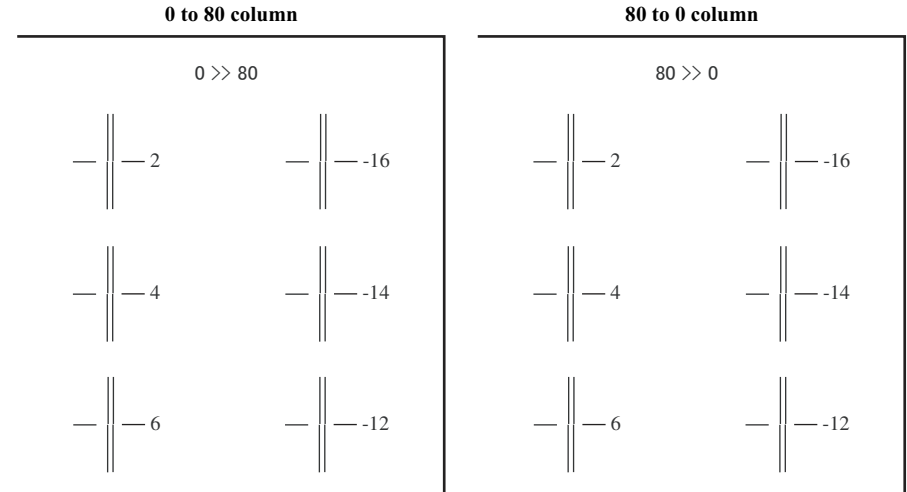

Figure 5-2. Head Angular Adjustment (Band) Pattern

How to Judge

Examine the printout patterns and enter the value (-16 to 16) for the most straight lines.

Additional information

When “16” or “-16” is the most straight lines, it indicates that the printhead is not installed correctly. Reassemble the printhead and carry out this adjustment again.

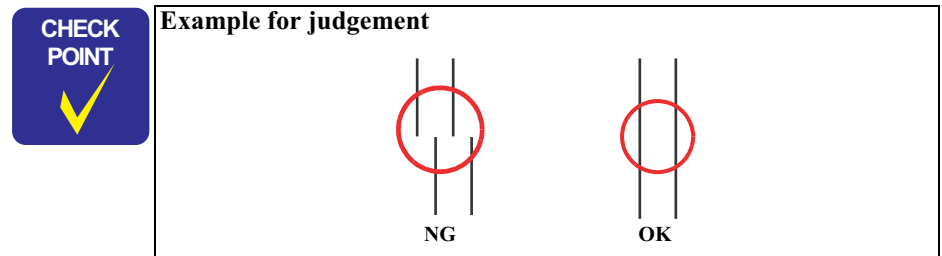

□ Microweave Pattern

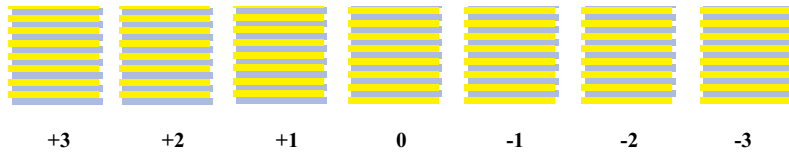

Figure 5-3. Head Angular Adjustment (Microweave) Pattern

How to Judge

Examine the printout +3 to -3 patterns and select the value for the group of which the gaps between the 2 color bars are the smallest.

Additional information

If no appropriate pattern is found, reassemble/replace the Print Head.

CHECK
POINT

Example for judgement

OK

NG

5.2.3 Bi-D Adjustment

The pattern shown below is printed for each of the 7 print modes.

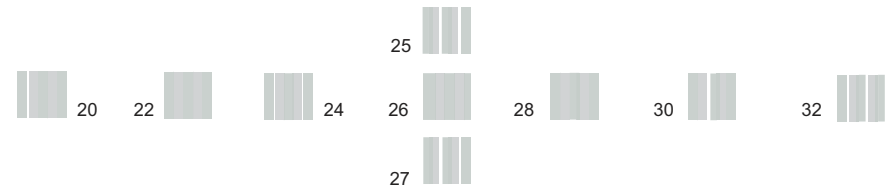

Figure 5-4. Bi-D Adjustment Pattern

How to Judge

Find the pattern with no gaps or overlaps of the left and right pattern, and enter the value of that pattern.

Additional information

If an appropriate pattern is not printed, enter the nearest value and then print the patterns again.

CHECK
POINT

Example for judgement

NG

OK

NG

5.2.4 PW Adjustment/First Dot Position Adjustment

Patterns are printed as shown below.

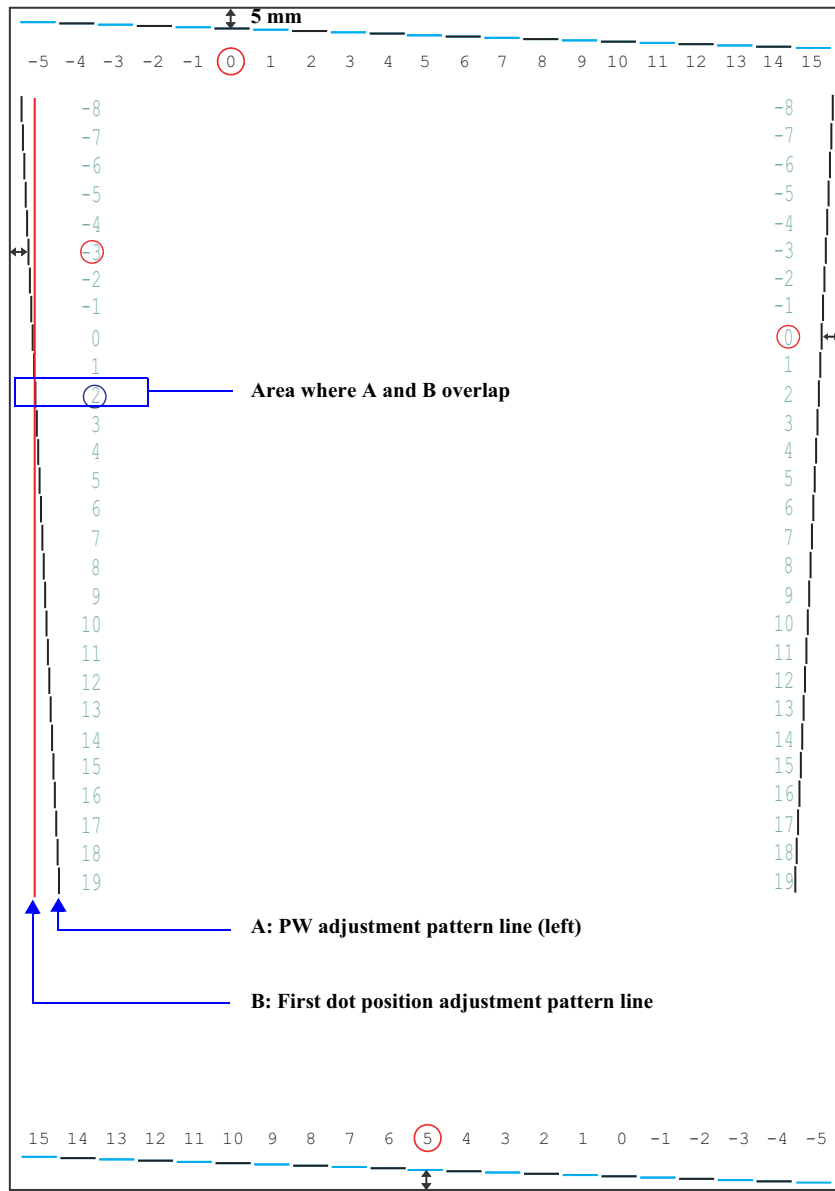

Figure 5-5. PW/First Dot Position Adjustment Pattern

- PW adjustment

How to Judge

Enter the value for the line that is exactly 5mm away from the paper edge for each of the left, right, top and bottom.

Example: In the left figure, enter “0” (top), “0” (right), “5” (bottom) and “-3” (left).

- First dot position adjustment

How to Judge

Enter the value for the point where the PW adjustment pattern line and the First dot position adjustment pattern line overlap on the left of the paper.

Example: In the left figure, enter “2” since the lines overlap at “2” position.

DURAKLIN

5.2.5 PF Adjustment

- PF- for standard print area

Patterns are printed as shown below.

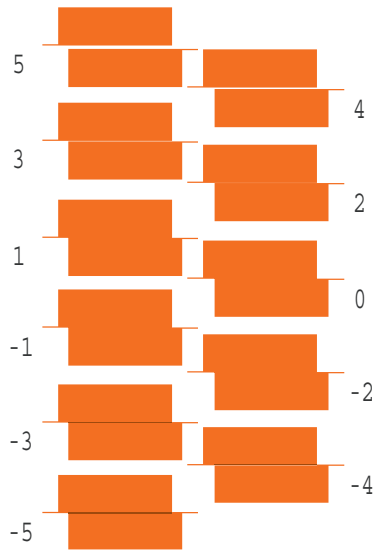
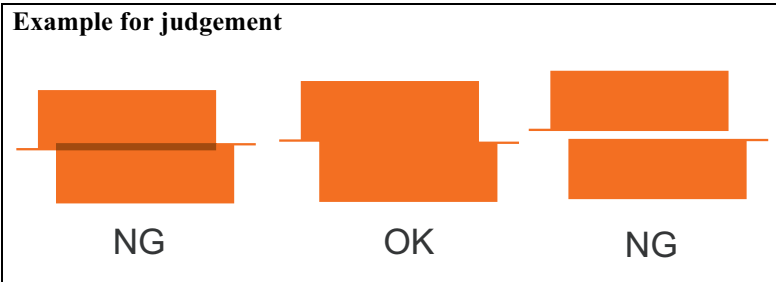

Figure 5-6. PF (standard print area) Adjustment Pattern

How to Judge

Enter the value for the group that has no gap or overlap between the upper and the lower patterns.



- PF- for bottom margin area

Patterns are printed as shown below.

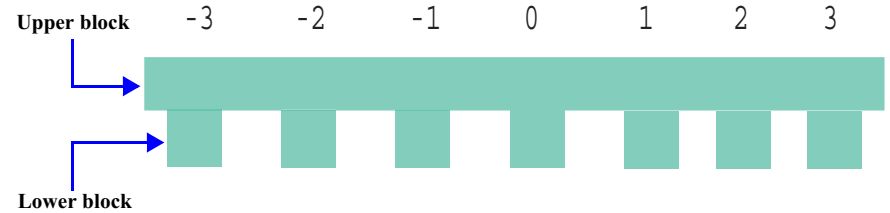

Figure 5-7. PF Adjustment (bottom margin area) Pattern

How to Judge

Enter the value for the one that has no gap or overlap between the upper block and the lower block.

Example: In the above figure, “0” should be selected.

Additional information

In case that all patterns have gap or overlap, select the value for the pattern which has the least gap or overlap, and print the pattern again.

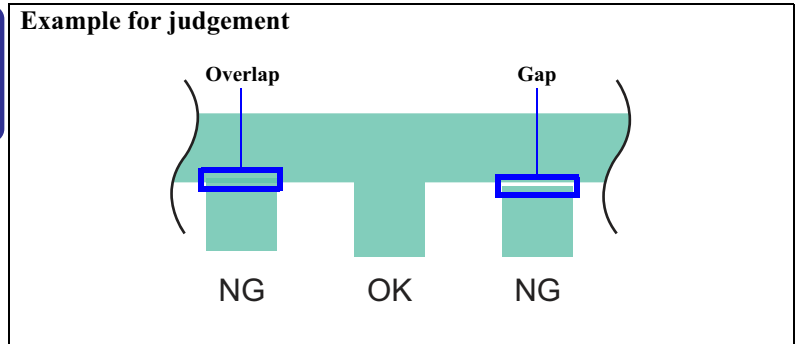

5.2.6 PG Adjustment

Described below is the platen gap (PG) adjustment.

- Purpose:
 - Adjust the distance between the head surface and the Paper Guide Front Assy (platen) properly and adjust the parallelism on the 0th column side and on the 80th columns side to ensure reliable print quality.
 - Once the Carriage Assy and/or Adjustment Bushes have been removed or whenever necessary for any other reason, make this adjustment to correct the deviation of the platen gap.

Table 5-5. PG Positions

Position	PG Size (mm)	Application for Printing (selected from PG flag list for normal/head rubbing)	Sequence Application
PG- <APG Home>	1.2	EPSON special thick paper PGPP, Postcards, Matte, etc.	Cleaning CR measurement, VH detection CR home position seek
PG typ. <Mechanical default>	1.7	Plain paper EPSON special thin paper, SF, etc. Rubbing with PG1.2 is avoided	
PG+	2.35	Envelopes Rubbing with PG1.2 and 1.7 is avoided	
PG++	4.2	CD-R printing	At ink replacement

- Things to be used
 - Thickness gauge: 1.15 mm (x2)
1.3 mm (x2)
 - Phillips screwdriver



- The thickness gauge to be used must be free from dust and dirt and from deformation. Be sure to clean it before use.
- Take care that the Print Head is not soiled or scratched.
- To ensure high accuracy of adjustment, install new ink cartridges in the carriage, and move the carriage right and left by pulling the belt without holding the carriage.



- Make this adjustment after installing the mechanism unit in the Housing Lower. (Install the Linear Scale after adjustment.) Refer to “4.4.1 Removing the Printer Mechanism” (p. 69)
- With EPSON Stylus Photo R280/R285/R290, four stages of PG setting are available by means of the APG Mechanism. However, make this adjustment with the mechanism in the minimum PG position (PG-: 1.2 mm). (Refer to “4.4.4 APG Unit” (p. 75) and below.)

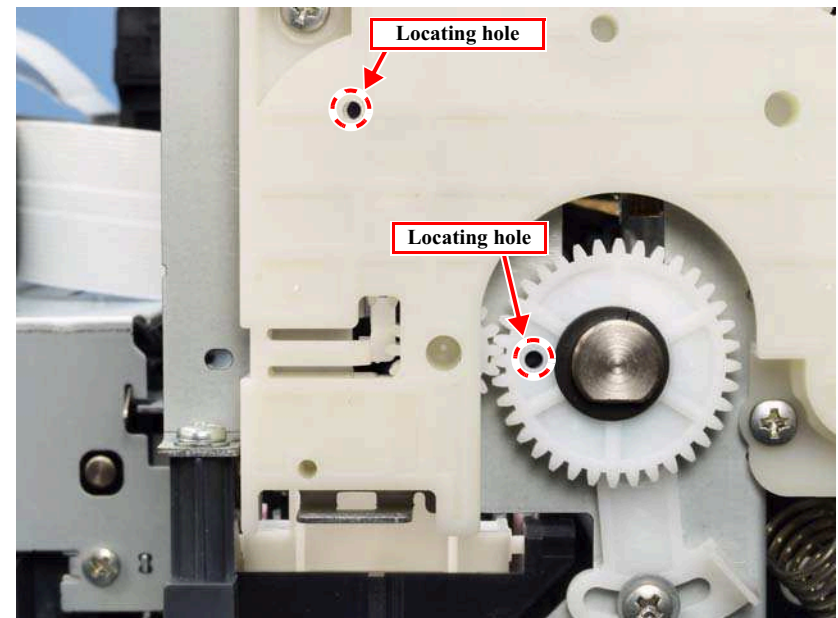

Figure 5-8. PG Position at PG Adjustment

□ Adjustment procedure

- Specified PG value: 1.2 ± 0.1 mm

1. Install new ink cartridges in the carriage.
2. Remove the Cable Holder Frame. (Fig. 4-73)
3. Check that the APG Assy and the carriage are in the PG-position. (Fig. 5-8)
4. Move the carriage to the center of the platen, and place 1.15 mm thickness gauge on the left aligning its left edge with the second rib of the Front Paper Guide. And place another 1.15 mm thickness gauge on the right aligning its right edge with the rightmost rib of the Front Paper Guide. (Fig. 5-9)

NOTE: The thickness gauge must not be set over the leftmost rib on the Front Paper Guide.

5. Pull the Timing Belt to move the carriage to the left end.
6. If the carriage comes in contact with the gauge, adjust the Left Parallelism Bush to raise the carriage to a position where the Printhead does not come in contact with gauge.
7. Pull the Timing Belt to move the carriage to the right end.
8. If the carriage comes in contact with the gauge, adjust the Right Parallelism Bush to raise the carriage to a position where the Printhead does not come in contact with gauge.
9. Move the carriage to the middle area of the platen, and place 1.3 mm thickness gauges at the left and right ends of the platen.
10. Pull the Timing Belt to move the carriage to the left end.
11. If the carriage does not come in contact with the gauge, make the adjustment again.
12. Pull the Timing Belt to move the carriage to the right end.
13. If the carriage does not come in contact with the gauge, make the adjustment again.
14. Mark the indicated graduation position of the right and left Parallelism Bush, and tighten the screws.
(Screw tightening torque: 0.8 ± 0.1 N•m)

CAUTION

The Printhead must come in contact with the 1.3 mm thickness gauges but must not come in contact with the 1.15 mm thickness gauges.

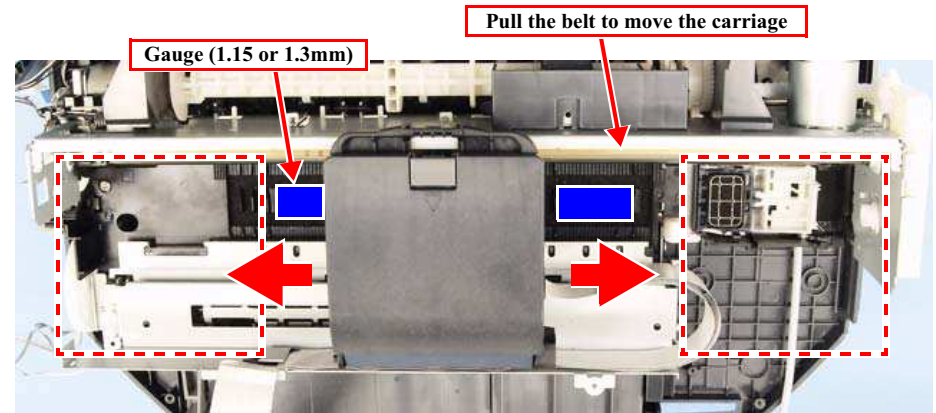

Figure 5-9. PG Adjustment 1

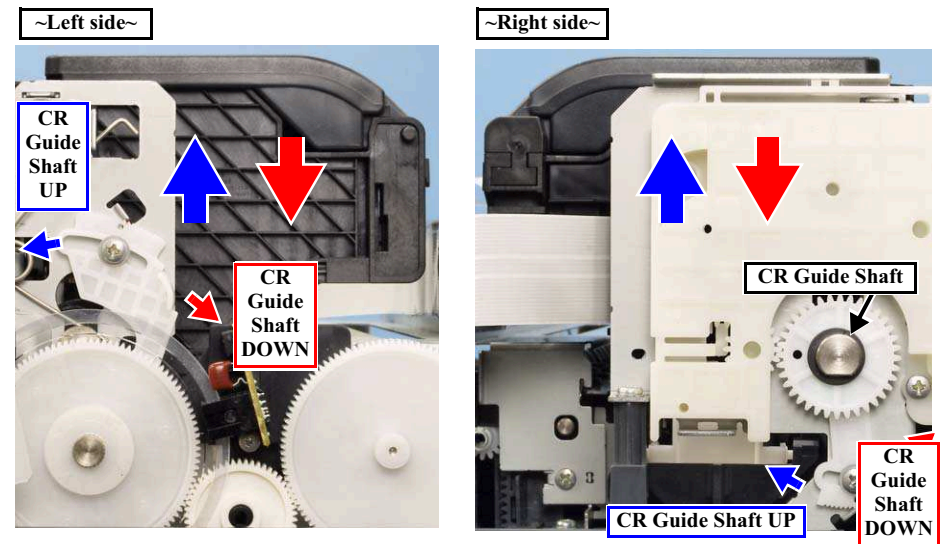

Figure 5-10. PG Adjustment 2

5.3 Banding Reduction System (BRS) Adjustment / Paper Feed Amount Profile (PFP) Correction

5.3.1 Overview

This section explains how to carry out BRS/PFP adjustments.



- For overview of BRS/PFP Adjustment, refer to Chapter 2 “2.3 Banding Reduction System (BRS) / Paper Feed Amount Profile Correction (PFP) (p. 26)
- Be sure to have a specified scanner ready beforehand as it is necessary to carry out the adjustment. Before scanning, confirm that the document table is free from any dirt or stain.

- Tools and paper required to perform the adjustment

Table 5-6. Tools and Paper for BRS/PFP Adjustment

	Tools/Paper	Product Code
Common	PFP Base scale	1453980
BRS	Matte Paper-Heavyweight (A4)	---
PFP	Premium Glossy Photo Paper (4 x 6)	---

- Specified Scanner to perform the adjustment



- Install the driver of the scanner to the PC in advance.
- As the profile required for the adjustment is not prepared for scanners other than the ones specified below, BRS/PFP Adjustment can not be carried out by the other scanners.

The following are the scanners that can be used for scanning the pattern in BRS/PFP adjustment. When starting up the adjustment program, select the scanner to use.

Table 5-7. Specified Scanner for BRS/PFP Adjustment

Model Name	Sensor type	Remarks
Perfection 4990 Photo	CCD	
Perfection V700 Photo	CCD	
Stylus Photo RX560/RX580/RX590	CIS	Use the internal scanner.
Stylus Photo RX585/RX595/RX610	CIS	Use the internal scanner.
Stylus Photo RX680/RX685/RX690	CIS	Use the internal scanner.



- Depending on the sensor type of the scanner to use for the adjustment, drying time required after the BRS adjustment pattern has been printed differs. For PFP adjustment pattern/PFP check pattern, drying time is not required.
- For “CCD” sensor:
Printed pattern can be scanned straight away. (Drying time of about 2 minutes is recommended.)
 - For “CIS” sensor:
Printed pattern needs to be dried more than 5 minutes.

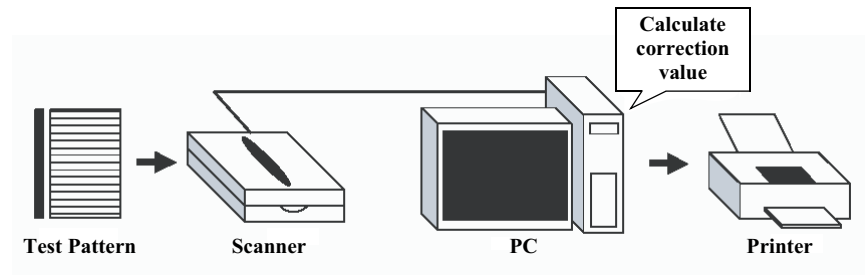

Figure 5-11. System Configuration

□ Adjustment Flow

Carry out the adjustment following the adjustment flow below.

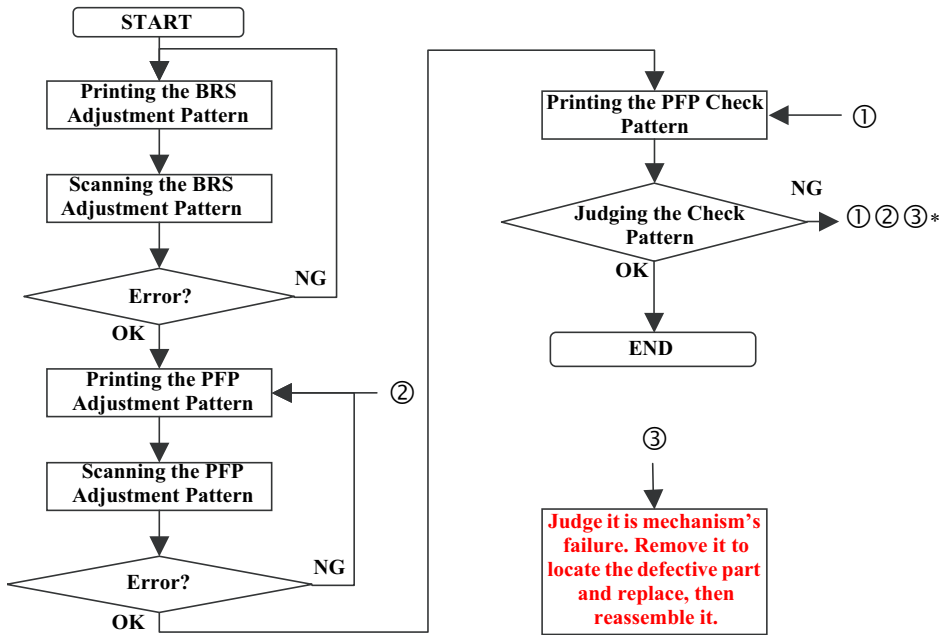

Figure 5-12. BRS/PFP Adjustment Flow

Note*: When a PFP pattern is judged as NG, repeat the steps as described below.
 First time NG: retry from ① step
 Second time NG:retry from ② step
 Third time NG: perform ③ step



When an error is displayed in the Adjustment program, check the points below, then carry out the adjustment again. If an error occurs even after checking the points below, change the scanner with a different one and carry out the adjustment again.

1. Check that the printer that printed the pattern and the printer to register the adjustment value is the same.
2. Check that the printed pattern is placed on the document table of the scanner correctly.
3. Check that there is no gap between the PFP Base Scale and the pattern printed sheet.
4. Check that the scanner glass surface and the PFP Base Scale is free from any dirt or dust.

DURAKLIN

5.3.2 Adjustment Procedure

5.3.2.1 BRS (Banding Reduction System) Adjustment

- Printing the BRS Adjustment Pattern
 1. Load A4 size Matte Paper-Heavyweight on the paper support.
 2. Select [BRS Adjustment] in the adjustment program.
 3. Click the [Print] button on the “1. Print Test Pattern” column to print the adjustment pattern.
 4. Let the printed pattern dry for more than 5 minutes if using CIS sensor type scanner.

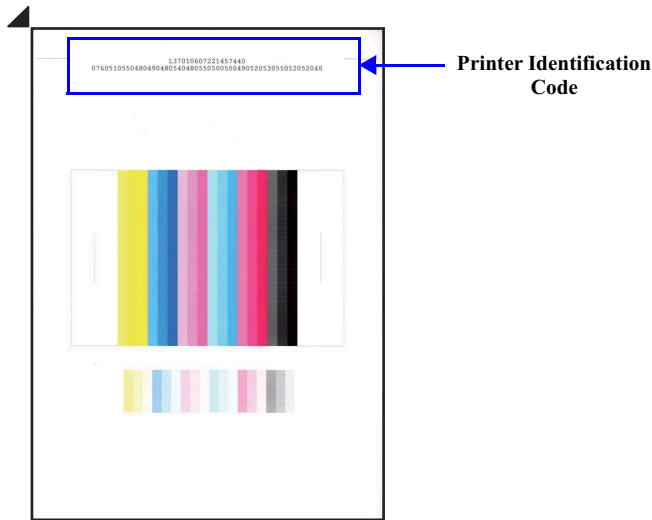

Figure 5-13. BRS Test Pattern



- In the Adjustment program, the identification code is used to distinguish whether the printer that printed the pattern and the printer to register the adjustment value is the same.
- Make sure to let the printed pattern dry for more than 5 minutes if using CIS sensor type scanner. When using CCD sensor type scanner, the printed pattern does not need to be dried before scanning. Refer to “Table 5-7. Specified Scanner for BRS/PFP Adjustment” (p.107)

- Scanning the BRS Adjustment Pattern
 5. Set the printed pattern and the PFP Base Scale on the document table and click the [Scan] button on the “3. Scan Test Pattern” column.
 6. According to the scanned result, BRS calibration values are automatically calculated and are written to the serial flash ROM. If an error occurs, check that the document table glass and the scale is clean, and the scale/adjustment pattern is not tilted, then repeat from step 5.

CAUTION

Be careful of the following when setting the PFP Base Scale, and the adjustment pattern on the scanner.

- Place the scale on the document glass aligning the scale corner with the scanner origin position.
- Place the pattern-printed sheet along the scale as shown in the figure below. Make sure to place it parallel to the scale, with no gaps.

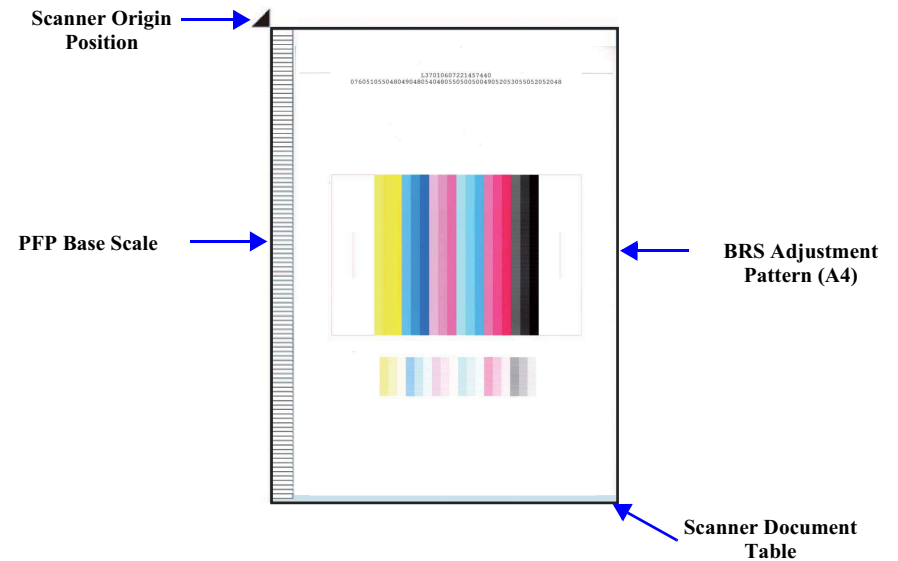

Figure 5-14. PFP Base Scale and BRS Adjustment Pattern Position (Viewed from the document glass of the scanner)

5.3.2.2 PFP Adjustment

- Printing the PFP Adjustment Pattern
 1. Load 4 x 6 Premium Glossy Photo Paper on the paper support.
 2. Select [PFP Adjustment] in the adjustment program.
 3. Click the [Print] button on the “1. Print Test Pattern” column to print the adjustment pattern.

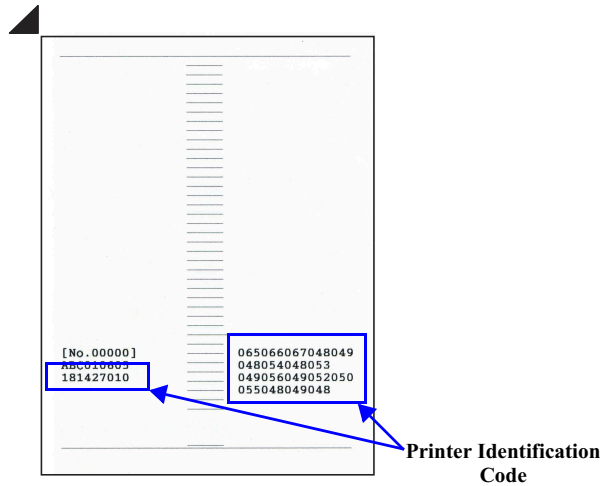

Figure 5-15. PFP Test Pattern



In the Adjustment program, the identification code is used to distinguish whether the printer that printed the pattern and the printer to register the adjustment value is the same.

- Scanning the PFP Adjustment Pattern
 4. Set the PFP Base Scale and the PFP test pattern on the document table and click the [Scan] button on the “3. Scan Test Pattern” column.
 5. According to the scanned result, PFP calibration values are automatically calculated and are written to the serial flash ROM. If an error occurs, check that the document table glass and the scale is clean, and the scale/adjustment pattern is not tilted, then repeat from step 4.



Be careful of the following when setting the PFP Base Scale and the adjustment pattern on the scanner.

- Place the scale on the document glass aligning the scale corner with the scanner origin position.
- Place the pattern-printed sheet along the scale as shown in the figure below. Make sure to place it parallel to the scale, with no gaps.

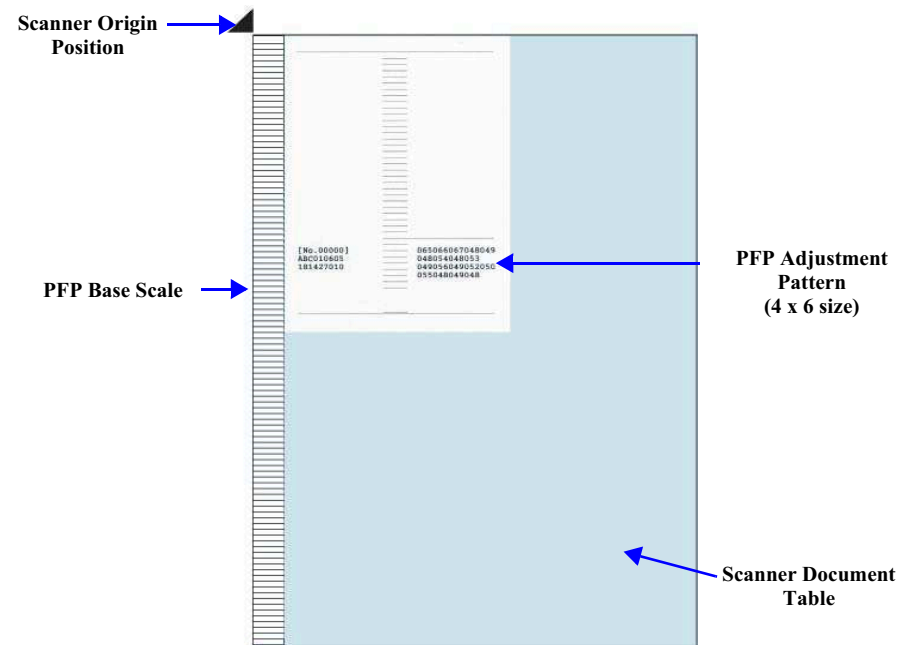

Figure 5-16. PFP Base Scale and PFP Adjustment Pattern Position (When viewed from the document glass of the scanner)

- Printing the PFP Check Pattern
- 6. Set 4 x 6 Premium Glossy Photo Paper on the paper support and click the [Print] Button on the “4. Print Check Pattern” column.

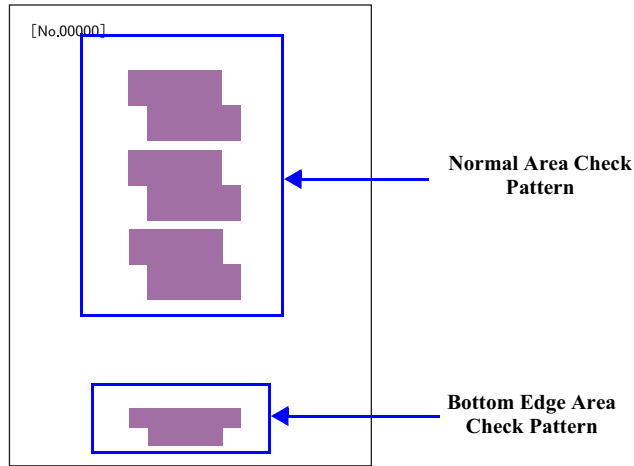

Figure 5-17. PFP Check Pattern

- Judging the Check Pattern
- 7. Referring to [Fig. 5-18](#) check that there is no white or overlapped bands in all the check patterns. If any bands are found, carry out the steps below.
 1. Re-print the check pattern to see if the bands appear again.
 2. When bands appear in Step 1, try the PFP adjustment again from the beginning.
 3. When bands appear even after the re- adjustment in step 2, determine that it is the mechanism failure and carry out check/reassemble of the parts that was removed/replaced.

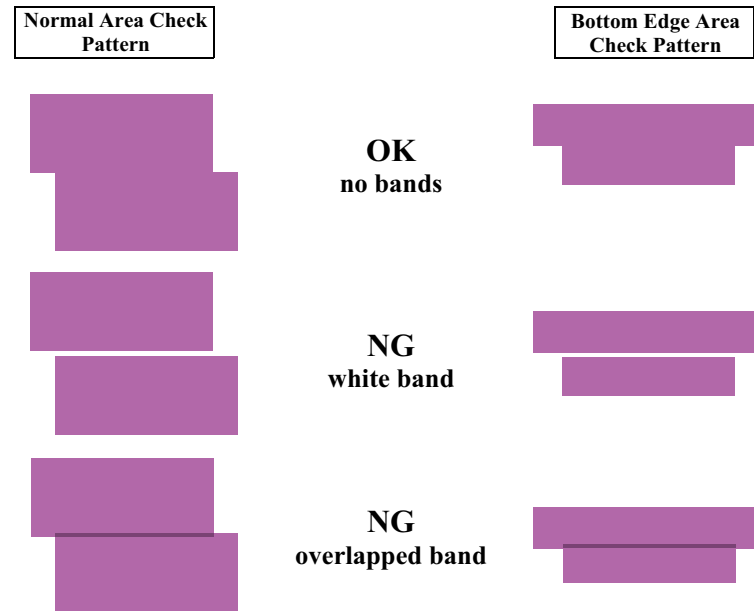

Figure 5-18. PFP Check Pattern Judging Standard

DURAKLIN

MAINTENANCE

CHAPTER
6

6.1 Overview

This section provides information to maintain the printer in its optimum condition.

6.1.1 Cleaning

This printer has no mechanical components which require regular cleaning except the Print Head. Therefore, when returning the printer to the user, check the following parts and perform appropriate cleaning if stain is noticeable.

CAUTION



- **Never use chemical solvents, such as thinner, benzene, and acetone to clean the exterior parts of the printer like the Housing. These chemicals may deform or deteriorate the components of the printer.**
- **Be careful not to damage any components when you clean inside the printer.**
- **Do not scratch the coated surface of the PF Roller Unit. Use soft brush to wipe off any dusts.**
- **Use a soft cloth moistened with alcohol to remove the ink stain.**
- **When using compressed air products; such as air duster, for cleaning during repair and maintenance, the use of such products containing flammable gas is prohibited.**

- Exterior parts
Use a clean soft cloth moistened with water, and wipe off any dirt. If the exterior parts have ink stain, use a cloth moistened with neutral detergent to wipe it off.
- Inside the printer
Use a vacuum cleaner to remove any paper dust.
- LD Roller
When paper loading function does not operate because of a drop in friction force of the LD Roller due to paper dust, use a soft cloth moistened with alcohol to remove the paper dust.

6.1.2 Service Maintenance

If any abnormal print (dot missing, white line, etc.) has occurred or the printer indicates the "Maintenance request error", take the following actions to clear the error. (This error is displayed in EPSON Status Monitor 3 and with LED.)

6.1.2.1 Print Head cleaning

When dot missing or banding appears on images, run the Print Head cleaning cycle.* The cleaning be activated from the control panel, the printer driver utility or the Adjustment program.

Note *: This printer has three manual cleaning modes. The appropriate cleaning mode is automatically selected and performed according to various conditions. The ink consumption amount for manual cleaning varies depending on the mode.

6.1.2.2 Maintenance request error

Ink is consumed also for cleaning and flashing operations. When the ink is used for cleaning and flashing operations, the ink is drained to the Waste Ink Pads via the Pump. The amount of the waste ink is stored as the waste ink counter into the EEPROM. When the waste ink counter has reached the limit of the absorbing capability of the Waste Ink Pads, the maintenance request error is displayed. This printer takes the ink evaporation amount into consideration, therefore the counter limit differs depending on how often printing is made.



For display of Maintenance request error, see the following.

- **Chapter3 "Troubleshooting" (p.27)**

When the maintenance request error appears, replace the Waste ink pads with a new one and reset the waste ink counter using the Adjustment program. If the waste ink counter is close to its limit, recommend that the Waste ink pads will be replaced with new one. This is because the "Maintenance request error" will may occur after returning the repaired product to the customer.

6.1.3 Lubrication

The type and amount of the grease used to lubricate the printer parts are determined based on the results of the internal evaluations. Be sure to apply the specified type and amount of the grease to the specified parts during servicing mentioned below.

- When parts that need lubrication is been replaced
- As the need arises during disassembly/reassembly of the printer

CAUTION

- Never use oil or grease other than those specified in this manual. Use of different types of oil or grease may damage the component and adversely affect the printer operation.
- Observe the specified amount. Never apply excess.

Table 6-1. Specified Lubricant

Type	Name	EPSON code	Supplier
Grease	G-71	1304682	EPSON
Grease	G-77	1455324	EPSON

- Refer to the following figures for the lubrication points.

LUBRICATION OF DRIVEN PULLEY

<Lubrication Points>
Four points where contact with the Main Frame

<Type>
G-71

<Application Amount>
ø 1 x 4 mm x 4 points

<Application Timing>
Apply before installing the Driven Pulley

<Remarks>
Apply with Injector

Figure 6-1. Lubrication of Driven Pulley (1)

<Lubrication Points>
Two points on bushings for the Pulley Shaft
One point at the center of the Pulley Shaft

<Type>
G-71

<Application Amount>
ø 1 x 1 mm x 3 points

<Application Timing>
Apply before installing the Driven Pulley

<Remarks>
Apply with Injector

Figure 6-2. Lubrication of Driven Pulley (2)

<Lubrication Points>
Two points on the side of the Pulley

<Type>
G-71

<Application Amount>
ø 1 x 1 mm x 2 points

<Application Timing>
Apply after installing the Driven Pulley

<Remarks>
Apply with Injector

Figure 6-3. Lubrication of Driven Pulley (3)

LUBRICATION OF FRONT PAPER GUIDE ASSY

<p style="text-align: center;">Front Paper Guide Assy (left)</p> 	<p><Lubrication Points> PF Roller Shaft, EJ Roller Shaft and Bushing (3 points)</p> <p><Type> G-71</p> <p><Application Amount> ø 1 x 3 mm x 3 points</p> <p><Application Timing> Apply after installing the Front Paper guide</p> <p><Remarks> Apply with Injector <input type="checkbox"/> Make sure that the coated part of the PF Roller Shaft and rubber rollers on the EJ Roller are free from grease.</p>
--	---

Figure 6-4. Lubrication of Front Paper Guide Assy (1)

<p style="text-align: center;">Front Paper Guide Assy (right)</p> 	<p><Lubrication Points> PF Roller Shaft, EJ Roller Shaft and Bushing (2 points)</p> <p><Type> G-71</p> <p><Application Amount> ø 1 x 3 mm x 2 points</p> <p><Application Timing> Apply after installing the Front Paper guide</p> <p><Remarks> Apply with Injector <input type="checkbox"/> Make sure that the coated part of the PF Roller Shaft and rubber rollers on the EJ Roller are free from grease.</p>
--	---

Figure 6-5. Lubrication of Front Paper Guide Assy (2)

LUBRICATION OF EJ FRAME ASSY

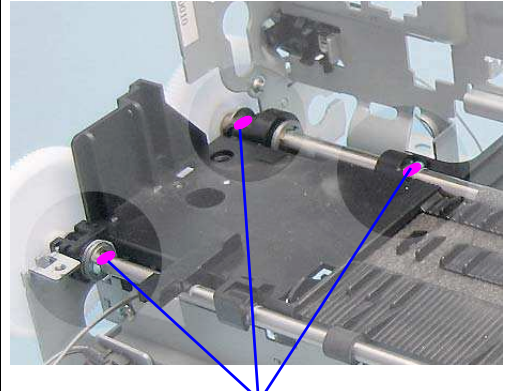
<p style="text-align: center;">EJ Frame Assy Bushing</p> <div style="display: flex; justify-content: space-around;"> <div style="text-align: center;"> <p>Left</p>  </div> <div style="text-align: center;"> <p>Right</p>  </div> </div>	<p><Lubrication Points> EJ Frame Assy Busing (Left/Right back side)</p> <p><Type> G-71</p> <p><Application Amount> ø1 x 1mm x 2 points (Right busing, both inner sides) ø1 x 3mm x 2 points (Left busing, both inner sides)</p> <p><Application Timing> Apply before installing the EJ Frame</p> <p><Remarks> Apply with Injector <input type="checkbox"/> Apply to the both inner sides of the left/right bushings.</p>
---	--

Figure 6-6. Lubrication of EJ Frame Assy

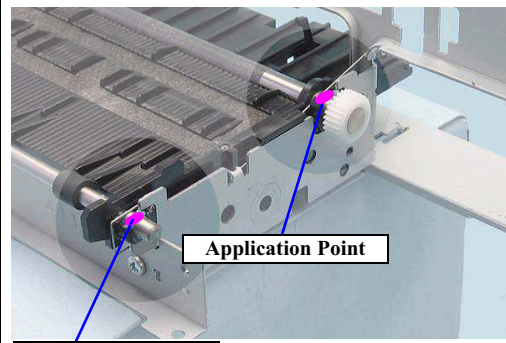
<p style="text-align: center;">Front Frame contact point (left)</p> 	<p><Lubrication Points> Contact point between the Front Frame and the PE Frame Assy (2 points)</p> <p><Type> G-71</p> <p><Application Amount> ø1 x 7mm (Left rib) ø1 x 3mm (Left notch for spring)</p> <p><Application Timing> Apply before installing the Front Frame</p> <p><Remarks> Apply with Injector <input type="checkbox"/> Apply to the inner edge of the notch for spring.</p>
---	---

Figure 6-7. Lubrication of the Front Frame (1)

<p>Front Frame contact point (right)</p>	<p><Lubrication Points> Contact position of the Front Frame and the PE Frame Assy (2 points)</p>
	<p><Type> G-71</p> <p><Application Amount> ø1 x 7mm (Right rib) ø1 x 3mm (Right Spring Bushing)</p> <p><Application Timing> Apply before installing the Front Frame</p> <p><Remarks> Apply with Injector <input type="checkbox"/> Apply to the inner edge of the notch for spring.</p>

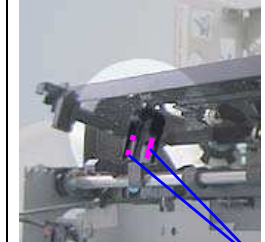
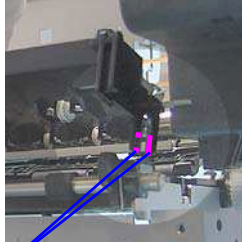
Figure 6-8. Lubrication of the Front Frame (2)

LUBRICATION OF CR UNIT

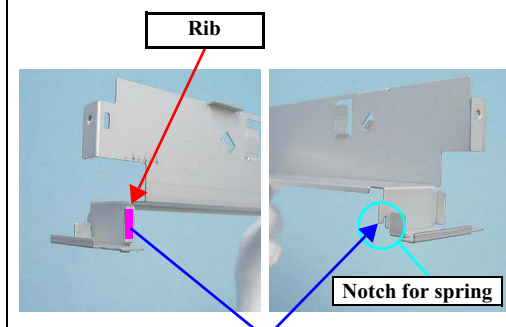
<p>Main Frame (upper rear)</p> 	<p><Lubrication Points> On the back of the Main Frame where contact with the CR Unit</p> <p><Type> G-71</p> <p><Application Amount> 160 ± 20mg</p> <p><Application Timing> Apply after installing the CR Unit</p> <p><Remarks> Apply with Injector <input type="checkbox"/> Do not apply to the both ends (40mm from edge) <input type="checkbox"/> Move the CR Unit the left/right to spread the grease evenly.</p>
--	--

Figure 6-9. Lubrication of the Main Frame (1)

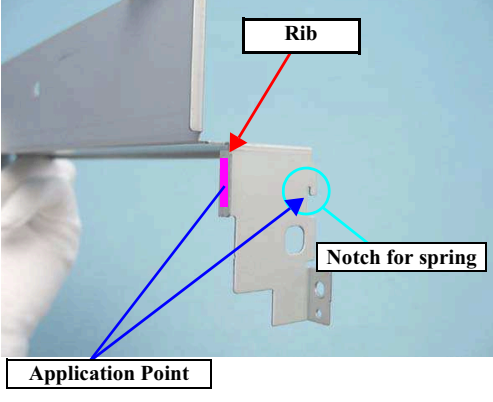
<p>PG Cam on both ends of CR Shaft</p> 	<p><Lubrication Points> On the PG Cams attached to the both ends of the CR Shaft</p> <p><Type> G-71</p> <p><Application Amount> ø 1 x 5mm x 3 points</p> <p><Application Timing> Apply after installing the CR Shaft</p> <p><Remarks> Apply with Injector</p>
---	---

Figure 6-10. Lubrication of the CR Shaft PG Cam

<p>CR Shaft Retaining Spring</p> 	<p><Lubrication Points> On the both ends of the CR Shaft to where its retaining springs are attached.</p> <p><Type> G-71</p> <p><Application Amount> ø 1 x 5 mm x 2 points</p> <p><Application Timing> Apply before installing the Spring</p> <p><Remarks> Apply with Injector</p>
--	--

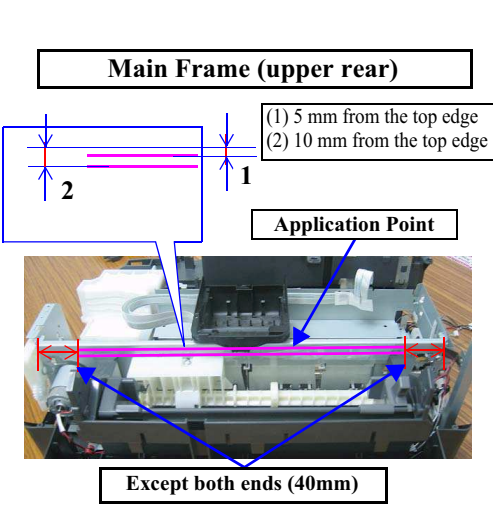
Figure 6-11. Lubrication for the CR Shaft Retaining Spring

	<p><Lubrication Points> Contact point between CR Unit and the CR Shaft</p> <p><Type> G-71</p> <p><Application Amount> 210 ± 20mg x 2 points</p> <p><Application Timing> Apply before installing the CR Unit</p> <p><Remarks> Apply with Injector <input type="checkbox"/> After lubrication, move the CR Shaft to left and right by 60mm while rotating it, to spread the grease evenly. <input type="checkbox"/> Make sure that the Timing Belt is free from grease.</p>
--	---

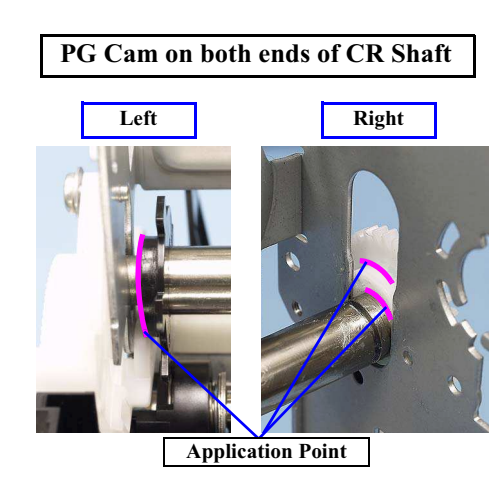
Figure 6-12. Lubrication of the CR Shaft (1)

	<p><Lubrication Points> Lubrication holes of the Carriage Unit</p> <p><Type> G-71</p> <p><Application Amount> 210 ± 20mg x 2 points</p> <p><Application Timing> Apply before installing the CR Unit</p> <p><Remarks> Apply with Injector <input type="checkbox"/> Apply grease from the two lubrication holes. <input type="checkbox"/> Make sure that the Timing Belt is free from grease.</p>
--	---

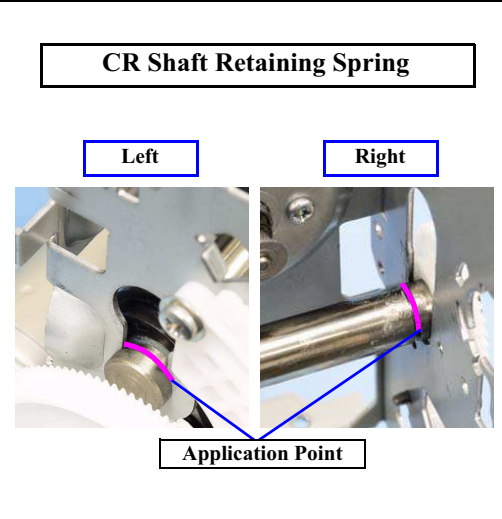
Figure 6-13. Lubrication of the CR Shaft (2)

LUBRICATION OF INK SYSTEM

	<p><Lubrication Points> On the Main Frame where the clutch gear and spring of the Ink System contact</p> <p><Type> G-71</p> <p><Application Amount> ø 1 x 1 circle</p> <p><Application Timing> Apply before installing the Ink System</p> <p><Remarks> Apply with Injector</p>
--	--

Figure 6-14. Lubrication of the I/S

LUBRICATION OF APG UNIT

	<p><Lubrication Points> Around the upper part of the shafts on the APG Unit. (5 points)</p> <p><Type> G-71</p> <p><Application Amount> ø 1 x 1 circle x 5 points</p> <p><Application Timing> Disassemble the APG Unit to apply the grease before installing it.</p> <p><Remarks> Apply with Injector</p>
--	--

Figure 6-15. Lubrication of the APG Unit (1)

<p>Rim of the APG Unit Spur Gear 28.8</p>	<p><Lubrication Points> Around the rim of the Spur Gear 28.8</p>
	<p><Type> G-71</p>
<p>Application Point</p>	<p><Application Amount> ø 1 x 1 circle</p>
<p><Application Timing> Apply before installing the APG Unit</p>	<p><Remarks> Apply with Injector</p>

Figure 6-16. Lubrication of the APG Unit (2)

<p>LD Roller Shaft (Curved surface)</p>	<p><Lubrication Points> Contact point between the LD Roller Shaft and the Hopper, ASF Gear</p>
<p>USB I/F side</p>	<p>Clutch side</p>
	
<p>Application Point</p>	<p>Application Point</p>
<p><Type> G-71</p>	<p><Application Amount> ø 1 x 10mm x 3 points</p>
<p><Application Timing> Apply before installing the ASF Unit</p>	<p><Remarks> Apply with Injector <input type="checkbox"/> Rotate the LD Roller Shaft so that the Curved/Flat surface face up, then apply grease to the specified parts.</p>

Figure 6-18. Lubrication of the LD Roller Shaft (1)

LUBRICATION OF ASF UNIT

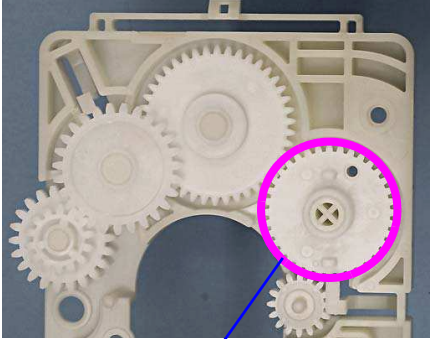
<p>Hole for LD Roller on ASF Unit</p>	<p><Lubrication Points> Inner edge of the hole on the ASF Unit where the LD Roller Shaft is put through</p>
	<p><Type> G-71</p>
<p>Application Point</p>	<p><Application Amount> 1 to 2 circles (inner edge) x 2 points</p>
<p><Application Timing> Apply before installing the LD Roller Assy</p>	<p><Remarks> Apply with Cotton bud</p>

Figure 6-17. Lubrication of the ASF Unit

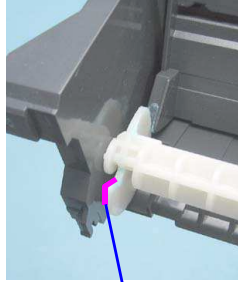
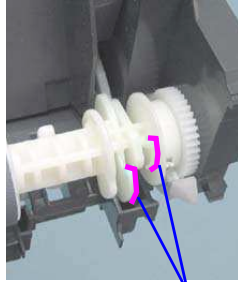
<p>LD Roller Shaft (Flat surface)</p>	<p><Lubrication Points> Contact point between the LD Roller Shaft and the Hopper, ASF Gear</p>
<p>USB I/F side</p>	<p>Clutch side</p>
	
<p>Application point (1)</p>	<p>Application point (2)</p>
<p><Type> G-71</p>	<p><Application Amount> (1) ■ :ø 1 x 20mm x 2 points (2) ■ :ø 1 x 10mm</p>
<p><Application Timing> Apply before installing the ASF Unit</p>	<p><Remarks> Apply with Injector <input type="checkbox"/> Rotate the LD Roller Shaft so that the Curved/Flat surface face up, then apply grease to the specified parts.</p>

Figure 6-19. Lubrication of the LD Roller Shaft (2)

<p>LD Roller Shaft (Curved surface) (Ribs beside the LD Roller)</p>	<p><Lubrication Points> Contact point between the LD Roller and Hopper, ASF Gear</p>
	<p><Type> G-71</p>
	<p><Application Amount> ø 1 x 1/4-circle x 4 points</p>
	<p><Application Timing> Apply before assembling the LD Roller Holder</p>
	<p><Remarks> Apply with Injector <input type="checkbox"/> Rotate the LD Roller Shaft so that the Curved/Flat surface face up, then apply grease to the specified parts.</p>

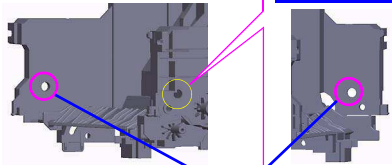
Figure 6-20. Lubrication of the LD Roller Shaft (3)

DURAKLIN

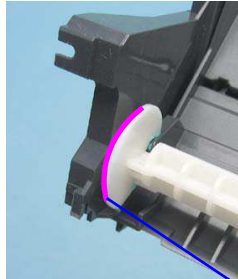
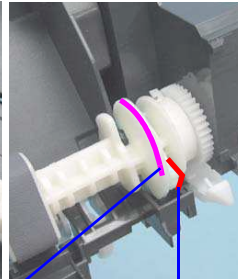
APPENDIX

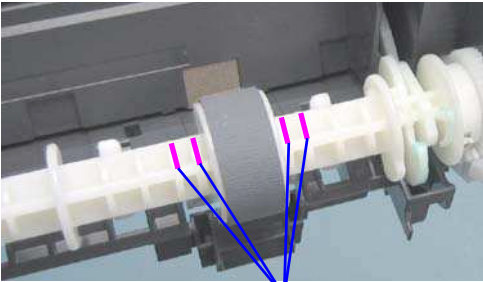
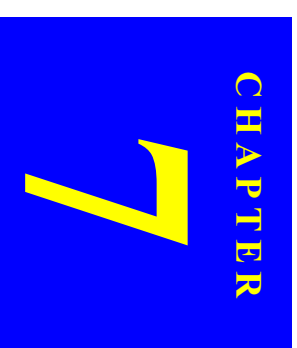

7.1 Exploded Diagram / Parts List

This manual does not provide exploded diagrams or parts list.

For the information, see SPI (Service Parts Information).

7.2 Electrical Circuits

The electric circuit diagrams below are shown at the following pages:

- Main Board (C691 MAIN)
- Panel Board (C691 PNL)
- Power Board (C691 PSB)
- Power Board (C691 PSE)

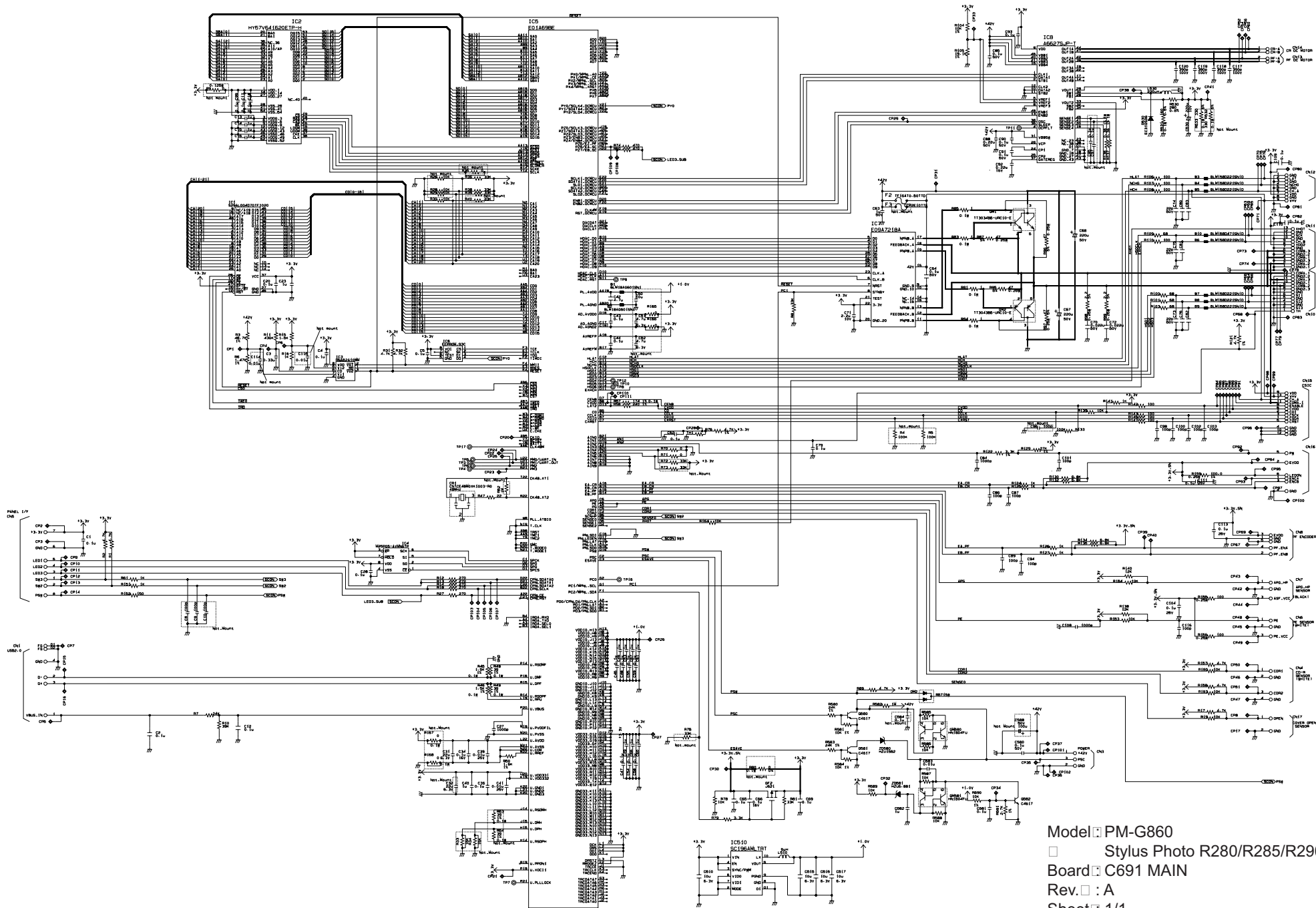

Model: PM-G860
Board: C691 MAIN
Rev.: A
Sheet: 1/1

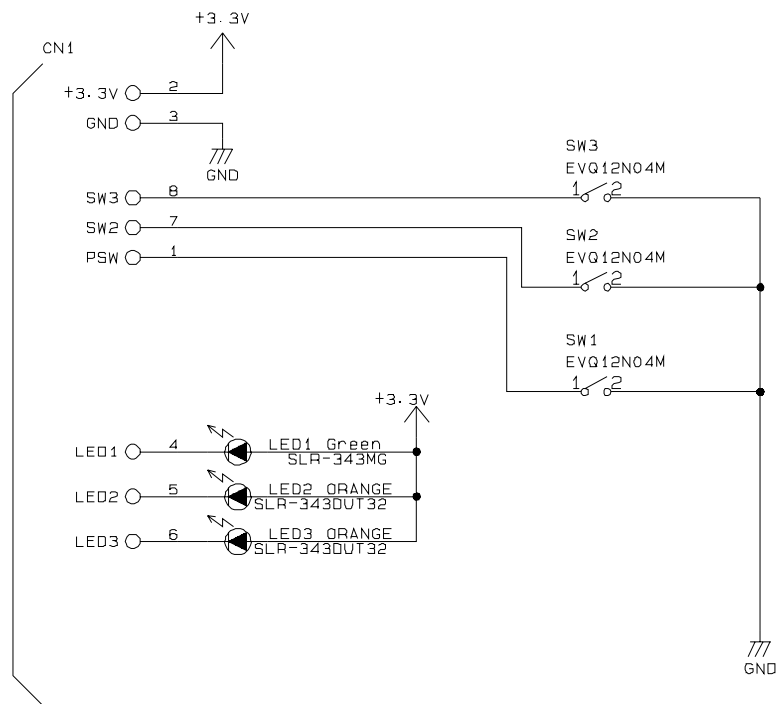

Model: PM-G860
Stylus Photo R280/R285/R290
Board: C691 PNL
Rev.: A
Sheet: 1/1

